

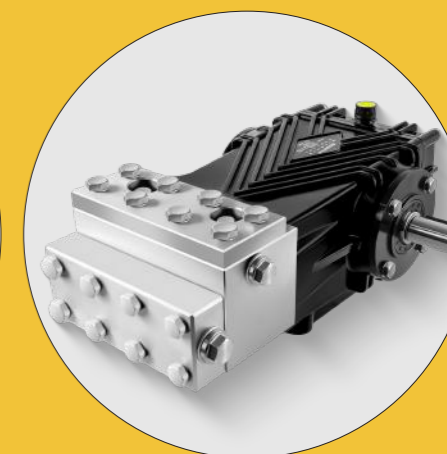

# 高压柱塞泵

HIGH PRESSURE  
PLUNGER PUMP

**用水创造价值**  
Create Value with Water Power

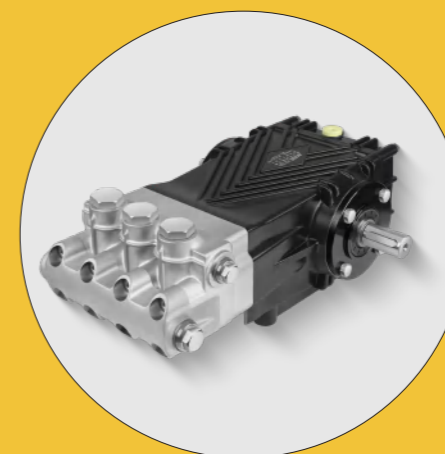

广州富森环保科技股份有限公司

☎ 133 1285 0022

✉ lsc@fussen.com.cn

🌐 www.fussen.com.cn

📍 广东省佛山市顺德区杏坛镇顺盈路9号中南高科科技产业园3栋

www.fussen.com.cn

# 公司介绍

## Company Profile

### 关于我们

广州富森环保科技有限公司自2001年成立以来,始终专注于高压水射流技术的研发与创新,在高压柱塞泵领域积累了深厚的技术经验。

凭借二十余年的技术沉淀,公司不断优化产品性能,以精湛的制造工艺和严格的质量控制,打造高品质、高可靠性的高压柱塞泵,广泛应用于船舶清洗、工业除漆除锈、石油化工、建筑清洗等多个领域,赢得市场的广泛认可。



专业化



国际化



品牌化



### 专业化

#### 专业高压清洗技术

高压清洗机作为清洗系统核心设备,其稳定性、工作效率直接决定整体作业效果。富森深入洞察不同工况与行业需求,研发出多款适应不同压力等级、流量范围及介质环境的高压清洗解决方案覆盖多种应用场景,满足多行业实际使用需求。

富森的高压泵会根据不同型号与应用需求,选用陶瓷柱塞或合金钢柱塞,以确保长期运行中的可靠性能与耐用性。陶瓷柱塞具备优异的耐磨性和耐腐蚀性,光滑、低摩擦的表面能够有效延长密封件的使用寿命;而合金钢柱塞则具有更高的强度和抗冲击能力,适用于高压与重载工况。

配合高品质的水封与油封,富森高压泵能够保持稳定运行并拥有更长的使用寿命。对于条件更严苛的应用环境,富森还可提供耐腐蚀、耐高温的定制化密封方案,使高压泵在多种复杂工况下依然具备可靠稳定性、高效性能与卓越的耐久性。



### 国际化

#### 国际质量标准,产品覆盖全球

富森严格执行ISO9001质量管理体系,确保产品在设计、生产、检测和服务各个环节均符合国际高标准。所有高压柱塞泵均通过CE认证,符合国际安全标准,并广泛应用于欧洲、俄罗斯、中东及东南亚等多个国家和地区,以卓越的品质和可靠的性能赢得了全球客户的信赖。



### 品牌化

#### 品牌理念-用水创造价值

“用水创造价值”是富森始终秉持的品牌理念。公司不仅致力于提供高品质的高压柱塞泵,更不断推动高压水射流清洗技术的发展,以智能化、环保化和高效化的创新产品,引领行业迈向更高水平。

未来,公司将继续深耕技术研发与产品优化,为全球客户提供更加专业、高效、可靠的清洗设备与解决方案。

**25**年  
生产研发经验

**200+**  
专利

**5000** m<sup>2</sup>  
厂房面积



# 公司荣誉 Corporate Honors

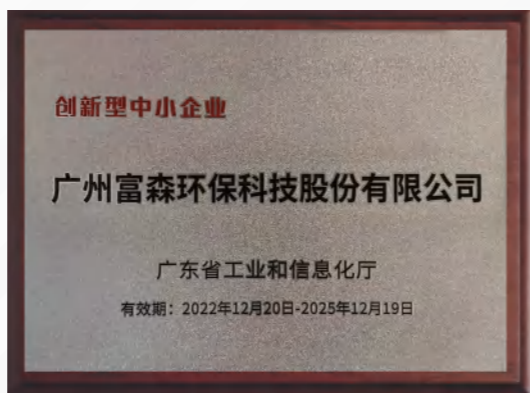
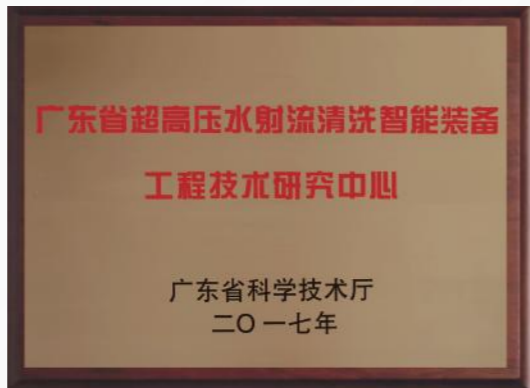

## 体系认证



## 专利证书



▶ 城市路面清洗



▶ 重型设备清洗



▶ 物业保洁



▶ 养殖区域清洗消毒



▶ 轿车清洗



▶ 锈迹污垢清除



▶ 船舶清洗



▶ 铁路清洁

# 高压柱塞泵解剖图

## ● 高低压水密封组件

采用高品质水封组件，其中高低压水封均采用耐磨、耐温的橡胶夹布材质制成，能够承受长时间的使用，并且在高达65摄氏度的高温环境下依然表现出色。

## ● 单向阀组件

阀笼采用耐高温、不易膨胀的工程塑料，而阀座和阀盖则采用316不锈钢材质。弹簧部分选用具有生缩性的特殊材料，以确保阀体具备长久的使用寿命。

## ● 泵头

阀笼采用耐高温、不易膨胀质，包括镀镍黄铜和不锈钢。这些材质具有出色的耐腐蚀性能。此外，泵头水道经过精心设计，确保水流量容积率高达99.8%

## ● 柱塞

经过精密加工的坚固陶瓷柱塞，适用于高负荷操作，具备出色的耐磨性和强大的抗腐蚀性能。

## ● 曲轴箱

曲轴箱经过精密铸造和氧化处理，表面涂有高强度的黑色电泳漆。此外，曲轴箱的顶部配备了高效的散热片，不仅能够有效散热，还能增强其结构强度

## ● 柱塞连杆

超强合金材质，负载强度高，使用寿命更长，确保运转安全稳定。

## ● 油塞

通风盖已移至曲轴箱后部，方便添加润滑油，也避免油溅和潜在泄漏。

## ● 观油窗

位于泵背后的观油窗使检查油位变得更加便捷。

## ● 曲轴

为提升曲轴的强度、使用寿命和耐久性，我们采用了精密锻造工艺以及硬化处理来制造曲轴。

## ● 油封

油封选用天然橡胶材质，配备不锈钢弹簧，以确保足够的张紧力。

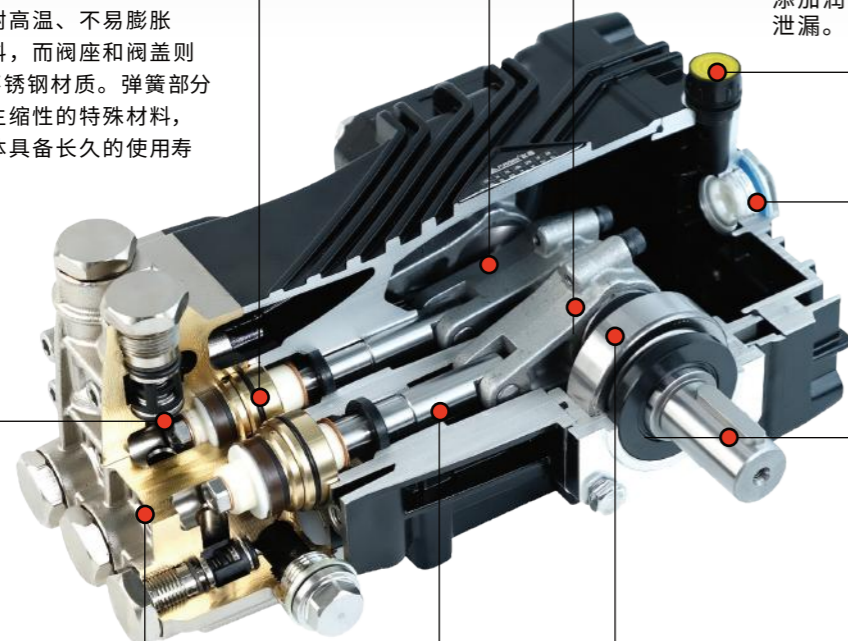

# 目录

## A系列

	FAB	02
	FABH	03
	FAN	04
	FANH	05
	FAS	06
	FASH	07

## B系列

	FBB	08
	FBN	09
	FBS	10

## C系列

	FCB	11
	FCN	12
	FCH	13
	FCC	14
	FCK	15

## C系列

	FCR	16
	FCM	17
	FCL	18

## D系列

	FDH	19
	FDK	20
	FDL	21

## E系列

	FEH	22
	FES	23
	FEK	24
	FEL	25
	FEK-G	26
	FES-G	27
	FFS-G	28
	FFS	29

# FAB



实心轴 Ø 24mm

产品参数

型号	转速	流量		压力			功率		重量	进水口		出水口
	RPM	L/min	GPM	Bar	Mpa	PSI	kW	HP		KG	Thread	
FAB1017	1450	10.0	2.6	170	17	2466	3.4	4.6	7.2	G 1/2	G 3/8	
FAB 1312	1450	13.0	3.4	120	12	1740	3.1	4.2	7.2	G 1/2	G 3/8	
FAB 1520	1450	15.0	4.0	200	20	2901	6.0	8.0	7.2	G 1/2	G 3/8	
FAB 1525	1450	15.0	4.0	250	25	3626	7.5	10.1	7.2	G 1/2	G 3/8	
FAB 1820	1450	18.0	4.8	200	20	2901	7.2	9.6	7.2	G 1/2	G 3/8	
FAB 1217	1750	12.1	3.2	170	17	2466	4.1	5.5	7.2	G 1/2	G 3/8	
FAB 1512	1750	15.7	4.1	120	12	1740	3.8	5.0	7.2	G 1/2	G 3/8	
FAB 1825	1750	18.1	4.8	250	25	3626	9.1	12.1	7.2	G 1/2	G 3/8	
FAB 2120	1750	21.7	5.7	200	20	2901	8.7	11.6	7.2	G 1/2	G 3/8	

尺寸图 (mm)

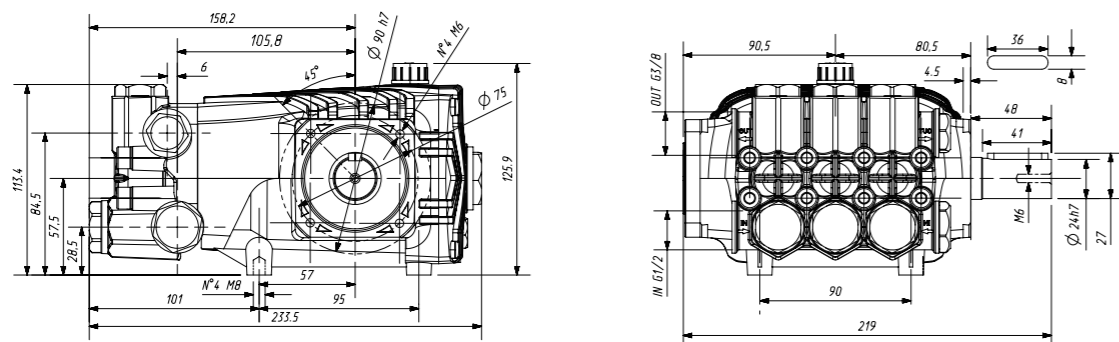

# FABH



空心轴 Ø 28mm

产品参数

型号	转速	流量		压力			功率		重量	进水口		出水口
	RPM	L/min	GPM	Bar	Mpa	PSI	kW	HP		KG	Thread	
FABH 1017	1450	10	2.6	170	17	2465	3.4	4.6	8	G 1/2	G 3/8	
FABH 1312	1450	13	3.4	120	12	1740	3.1	4.2	8	G 1/2	G 3/8	
FABH 1520	1450	15	4	200	20	2900	6	8	8	G 1/2	G 3/8	
FABH 1525	1450	15	4	250	25	3625	7.5	10.1	8	G 1/2	G 3/8	
FABH 1820	1450	18	4.8	200	20	2900	7.2	9.6	8	G 1/2	G 3/8	
FABH 1217	1750	12.1	3.2	170	17	2465	4.1	5.5	8	G 1/2	G 3/8	
FABH 1512	1750	15.7	4.1	120	12	1740	3.8	5	8	G 1/2	G 3/8	
FABH 1825	1750	18.1	4.8	250	25	3625	9.1	12.1	7.2	G 1/2	G 3/8	
FABH 2120	1750	21.7	5.7	200	20	2900	8.7	11.6	7.2	G 1/2	G 3/8	

尺寸图 (mm)

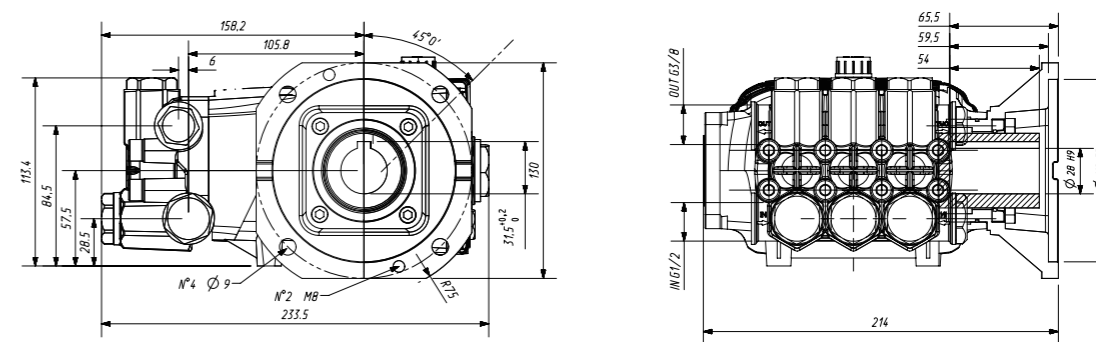

# FAN



实心轴 Ø 24mm

### 产品参数

型号	转速	流量		压力			功率		重量	进水口		出水口	
	RPM	L/min	GPM	Bar	Mpa	PSI	kW	HP		KG	Thread	Thread	Thread
FAN 1017	1450	10.0	2.6	170	17	2466	3.4	4.6	7.2	G 1/2	G 3/8		
FAN 1312	1450	13.0	3.4	120	12	1740	3.1	4.2	7.2	G 1/2	G 3/8		
FAN 1520	1450	15.0	4.0	200	20	2901	6.0	8.0	7.2	G 1/2	G 3/8		
FAN 1525	1450	15.0	4.0	250	25	3626	7.5	10.1	7.2	G 1/2	G 3/8		
FAN 1820	1450	18.0	4.8	200	20	2901	7.2	9.6	7.2	G 1/2	G 3/8		
FAN 1217	1750	12.1	3.2	170	17	2466	4.1	5.5	7.2	G 1/2	G 3/8		
FAN 1512	1750	15.7	4.1	120	12	1740	3.8	5.0	7.2	G 1/2	G 3/8		
FAN 1825	1750	18.1	4.8	250	25	3626	9.1	12.1	7.2	G 1/2	G 3/8		
FAN 2120	1750	21.7	5.7	200	20	2901	8.7	11.6	7.2	G 1/2	G 3/8		

### 尺寸图 (mm)

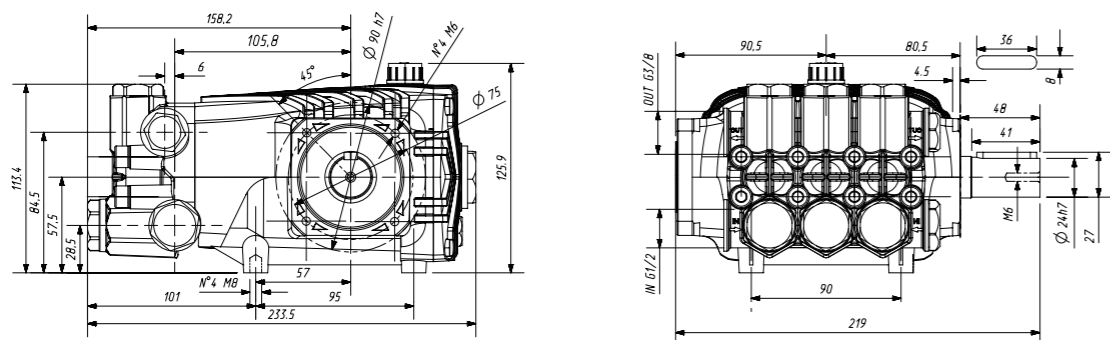

# FANH



空心轴 Ø 28mm

### 产品参数

型号	转速	流量		压力			功率		重量	进水口		出水口	
	RPM	L/min	GPM	Bar	Mpa	PSI	kW	HP		KG	Thread	Thread	Thread
FANH 1017	1450	10.0	2.6	170	17	2466	3.4	4.6	8	G 1/2	G 3/8		
FANH 1312	1450	13.0	3.4	120	12	1740	3.1	4.2	8	G 1/2	G 3/8		
FANH 1520	1450	15.0	4.0	200	20	2901	6.0	8.0	8	G 1/2	G 3/8		
FANH 1525	1450	15.0	4.0	250	25	3626	7.5	10.1	8	G 1/2	G 3/8		
FANH 1820	1450	18.0	4.8	200	20	2901	7.2	9.6	8	G 1/2	G 3/8		
FANH 1217	1750	12.1	3.2	170	17	2466	4.1	5.5	8	G 1/2	G 3/8		
FANH 1512	1750	15.7	4.1	120	12	1740	3.8	5.0	8	G 1/2	G 3/8		
FANH 1825	1750	18.1	4.8	250	25	3626	9.1	12.1	7.2	G 1/2	G 3/8		
FANH 2120	1750	21.7	5.7	200	20	2901	8.7	11.6	7.2	G 1/2	G 3/8		

### 尺寸图 (mm)

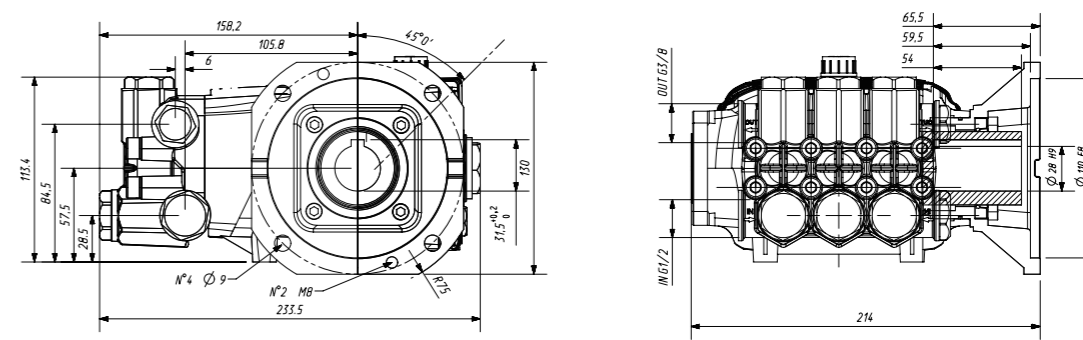

# FAS

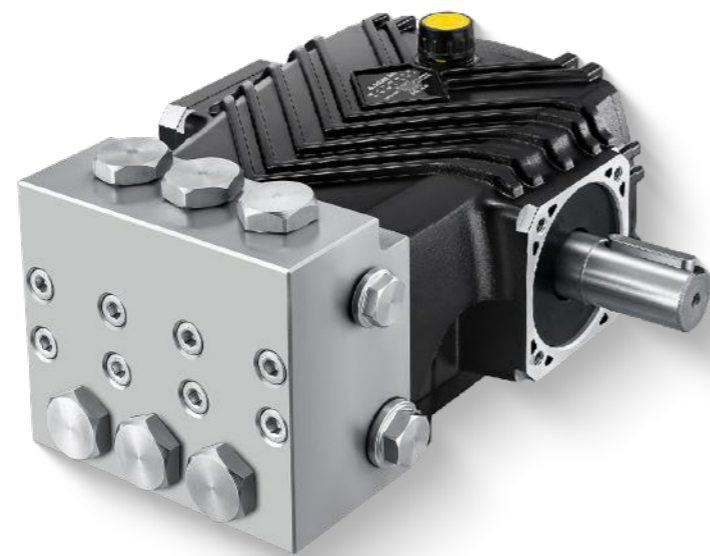

实心轴 Ø 24mm

产品参数

型号	转速	流量		压力			功率		重量	进水口		出水口
	RPM	L/min	GPM	Bar	Mpa	PSI	kW	HP		Thread	Thread	
FAS 1017	1450	10.0	2.6	170	17	2466	3.4	4.6	7.2	G 1/2	G 3/8	
FAS 1312	1450	13.0	3.4	120	12	1740	3.1	4.2	7.2	G 1/2	G 3/8	
FAS 1520	1450	15.0	4.0	200	20	2901	6.0	8.0	7.2	G 1/2	G 3/8	
FAS 1525	1450	15.0	4.0	250	25	3626	7.5	10.1	7.2	G 1/2	G 3/8	
FAS 1820	1450	18.0	4.8	200	20	2901	7.2	9.6	7.2	G 1/2	G 3/8	
FAS 1217	1750	12.1	3.2	170	17	2466	4.1	5.5	7.2	G 1/2	G 3/8	
FAS 1512	1750	15.7	4.1	120	12	1740	3.8	5.0	7.2	G 1/2	G 3/8	
FAS 1825	1750	18.1	4.8	250	25	3626	9.1	12.1	7.2	G 1/2	G 3/8	
FAS 2120	1750	21.7	5.7	200	20	2901	8.7	11.6	7.2	G 1/2	G 3/8	

尺寸图 (mm)

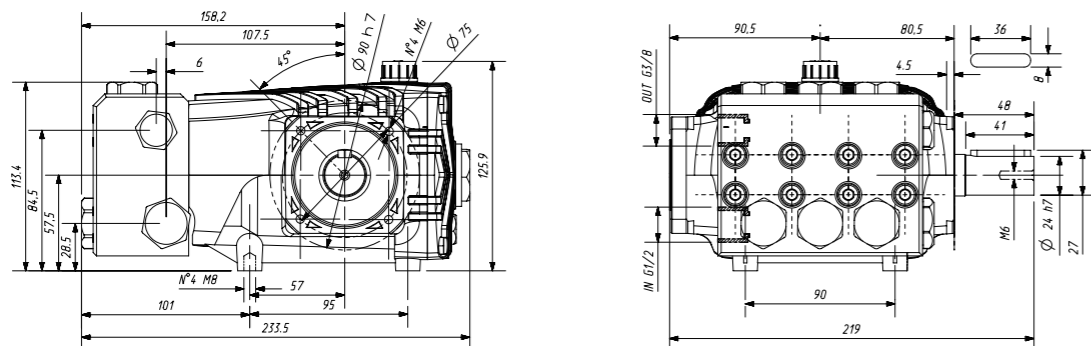

# FASH



空心轴 Ø 28mm

产品参数

型号	转速	流量		压力			功率		重量	进水口		出水口
	RPM	L/min	GPM	Bar	Mpa	PSI	kW	HP		Thread	Thread	
FASH 1017	1450	10.0	2.6	170	17	2466	3.4	4.6	8	G 1/2	G 3/8	
FASH 1312	1450	13.0	3.4	120	12	1740	3.1	4.2	8	G 1/2	G 3/8	
FASH 1520	1450	15.0	4.0	200	20	2901	6.0	8.0	8	G 1/2	G 3/8	
FASH 1525	1450	15.0	4.0	250	25	3626	7.5	10.1	8	G 1/2	G 3/8	
FASH 1820	1450	18.0	4.8	200	20	2901	7.2	9.6	8	G 1/2	G 3/8	
FASH 1217	1750	12.1	3.2	170	17	2466	4.1	5.5	8	G 1/2	G 3/8	
FASH 1512	1750	15.7	4.1	120	12	1740	3.8	5.0	8	G 1/2	G 3/8	
FASH 1825	1750	18.1	4.8	250	25	3626	9.1	12.1	7.2	G 1/2	G 3/8	
FASH 2120	1750	21.7	5.7	200	20	2901	8.7	11.6	7.2	G 1/2	G 3/8	

尺寸图 (mm)

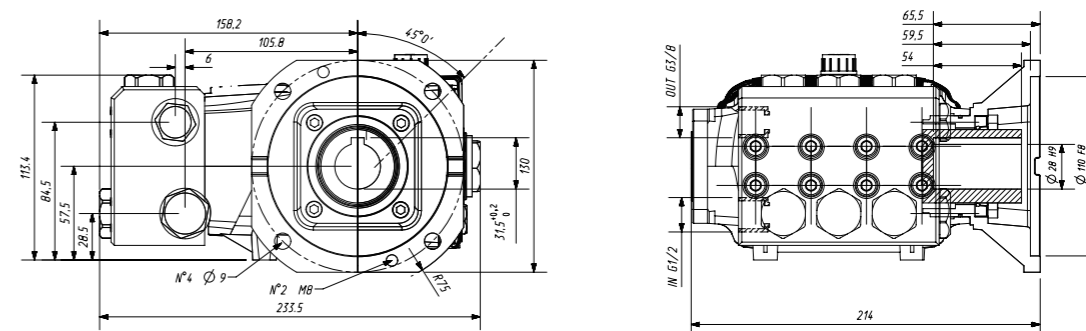

# FBB



实心轴 Ø 24mm

产品参数

型号	转速	流量		压力			功率		重量	进水口	出水口
	RPM	L/min	GPM	Bar	Mpa	PSI	kW	HP		Thread	Thread
FBB 1035	1450	10.0	2.6	350	35	5075	7.0	9.4	10.7	G 1/2	G 3/8
FBB 1530	1450	15.0	4.0	300	30	4350	9.0	12.1	10.7	G 1/2	G 3/8
FBB 1535	1450	15.0	4.0	350	35	5075	10.5	14.1	10.7	G 1/2	G 3/8
FBB 1828	1450	18.0	4.8	280	28	4060	10.1	13.5	10.7	G 1/2	G 3/8
FBB 2125	1450	21.0	5.5	250	25	3625	10.5	14.1	10.7	G 1/2	G 3/8
FBB 1235	1750	12.1	3.2	350	35	5075	8.4	11.3	10.7	G 1/2	G 3/8
FBB 1825	1750	18.1	4.8	250	25	3625	9.1	12.1	10.7	G 1/2	G 3/8
FBB 1835	1750	18.1	4.8	350	35	5075	12.7	17.0	10.7	G 1/2	G 3/8
FBB 2128	1750	21.7	5.7	280	28	4060	12.2	16.3	10.7	G 1/2	G 3/8
FBB 2525	1750	25.3	6.7	250	25	3625	12.7	17.0	10.7	G 1/2	G 3/8

尺寸图 (mm)

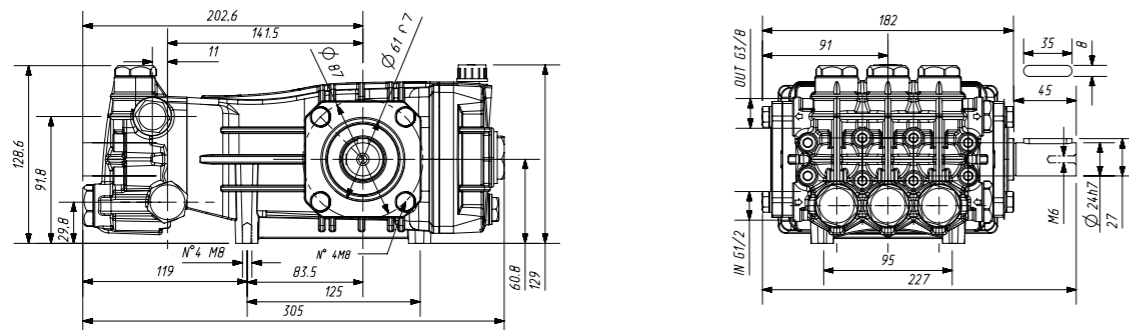

# FBN

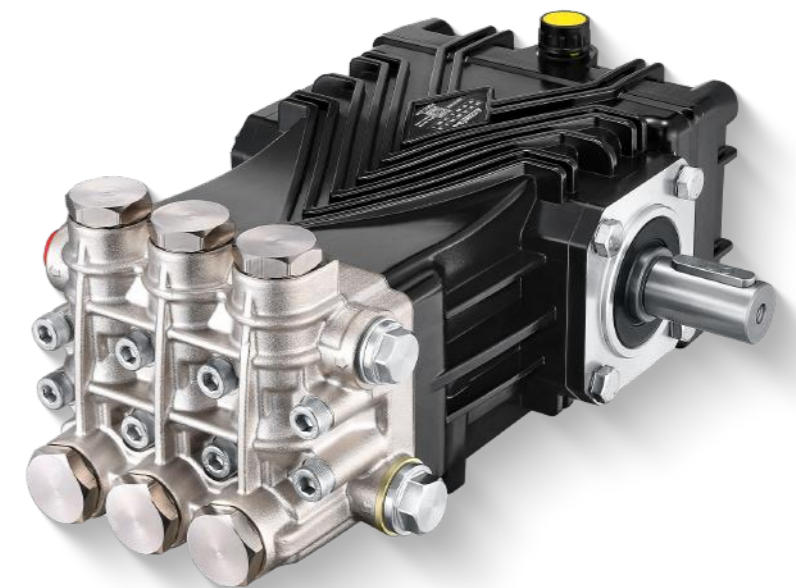

实心轴 Ø 24mm

产品参数

型号	转速	流量		压力			功率		重量	进水口	出水口
	RPM	L/min	GPM	Bar	Mpa	PSI	kW	HP		Thread	Thread
FBN 1035	1450	10.0	2.6	350	35	5075	7.0	9.4	10.7	G 1/2	G 3/8
FBN 1530	1450	15.0	4.0	300	30	4350	9.0	12.1	10.7	G 1/2	G 3/8
FBN 1535	1450	15.0	4.0	350	35	5075	10.5	14.1	10.7	G 1/2	G 3/8
FBN 1828	1450	18.0	4.8	280	28	4060	10.1	13.5	10.7	G 1/2	G 3/8
FBN 2125	1450	21.0	5.5	250	25	3625	10.5	14.1	10.7	G 1/2	G 3/8
FBN 1235	1750	12.1	3.2	350	35	5075	8.4	11.3	10.7	G 1/2	G 3/8
FBN 1825	1750	18.1	4.8	250	25	3625	9.1	12.1	10.7	G 1/2	G 3/8
FBN 1835	1750	18.1	4.8	350	35	5075	12.7	17.0	10.7	G 1/2	G 3/8
FBN 2128	1750	21.7	5.7	280	28	4060	12.2	16.3	10.7	G 1/2	G 3/8
FBN 2525	1750	25.3	6.7	250	25	3625	12.7	17.0	10.7	G 1/2	G 3/8
FBN 3620	1750	36.2	9.6	200	20	2900	14.5	19.4	10.7	G 1/2	G 3/8

尺寸图 (mm)

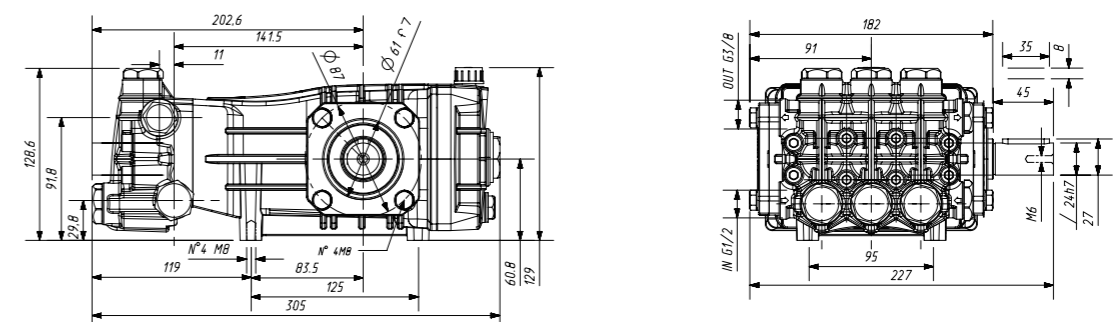

# FBS

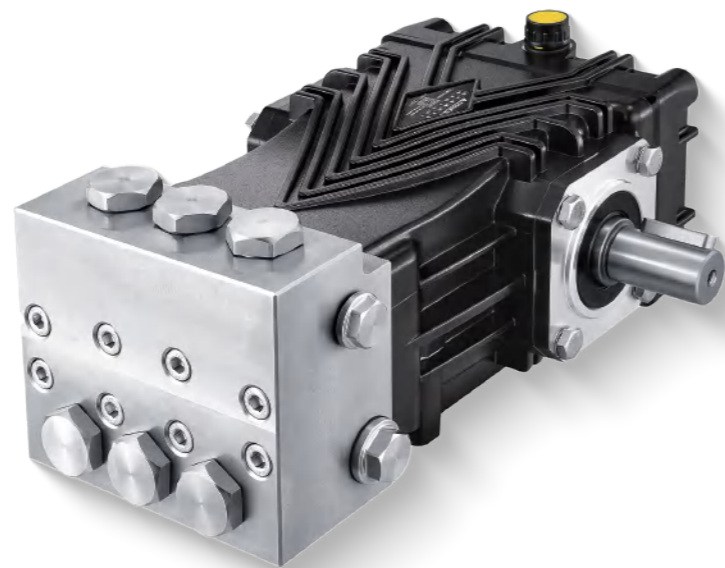

实心轴 Ø 24mm

产品参数

型号	转速	流量		压力			功率		重量	进水口	出水口
	RPM	L/min	GPM	Bar	Mpa	PSI	kW	HP		Thread	Thread
FBS 1035	1450	10.0	2.6	350	35	5075	7.0	9.4	13.5	G 1/2	G 3/8
FBS 1530	1450	15.0	4.0	300	30	4350	9.0	12.1	13.5	G 1/2	G 3/8
FBS 1535	1450	15.0	4.0	350	35	5075	10.5	14.1	13.5	G 1/2	G 3/8
FBS 1828	1450	18.0	4.8	280	28	4060	10.1	13.5	13.5	G 1/2	G 3/8
FBS 2125	1450	21.0	5.5	250	25	3625	10.5	14.1	13.5	G 1/2	G 3/8
FBS 3020	1450	30.0	7.9	200	20	2900	12.0	16.1	13.5	G 1/2	G 3/8
FBS 1235	1750	12.1	3.2	350	35	5075	8.4	11.3	13.5	G 1/2	G 3/8
FBS 1825	1750	18.1	4.8	250	25	3625	9.1	12.1	13.5	G 1/2	G 3/8
FBS 1835	1750	18.1	4.8	350	35	5075	12.7	17.0	13.5	G 1/2	G 3/8
FBS 2128	1750	21.7	5.7	280	28	4060	12.2	16.3	13.5	G 1/2	G 3/8
FBS 2525	1750	25.3	6.7	250	25	3625	12.7	17.0	13.5	G 1/2	G 3/8
FBS 3620	1750	36.2	9.6	200	20	2900	14.5	19.4	13.5	G 1/2	G 3/8

尺寸图 (mm)

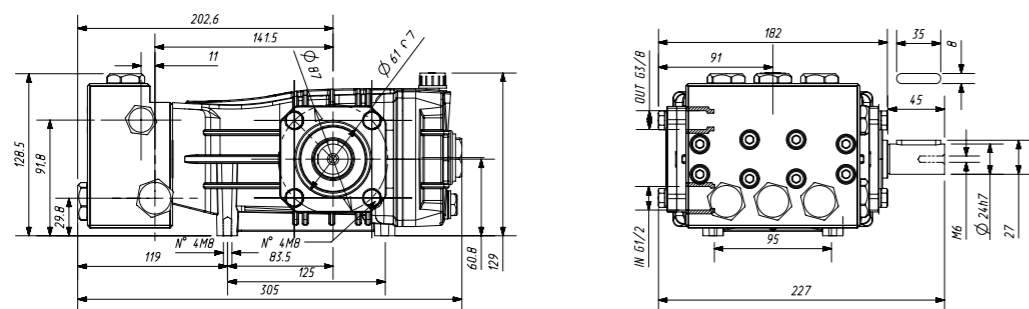

# FCB



实心轴 Ø 24mm

产品参数

型号	转速	流量		压力			功率		重量	进水口	出水口
	RPM	L/min	GPM	Bar	Mpa	PSI	kW	HP		Thread	Thread
FCB 1550	1450	16.0	4.2	500	50	7250	15.0	21.5	20.5	G 1/2	G 3/8
FCB 1860	1450	18.0	4.8	600	60	8700	22.0	29.0	20.5	G 1/2	G 3/8
FCB 2250	1450	22.0	5.8	500	50	7250	22.0	29.5	20.5	G 1/2	G 3/8
FCB 1850	1750	18.0	5.1	500	50	7250	18.0	25.9	20.5	G 1/2	G 3/8
FCB 2260	1750	22.0	5.7	600	60	8700	26.4	35.0	20.5	G 1/2	G 3/8
FCB 2650	1750	26.0	7.0	500	50	7250	26.6	35.6	20.5	G 1/2	G 3/8

尺寸图 (mm)

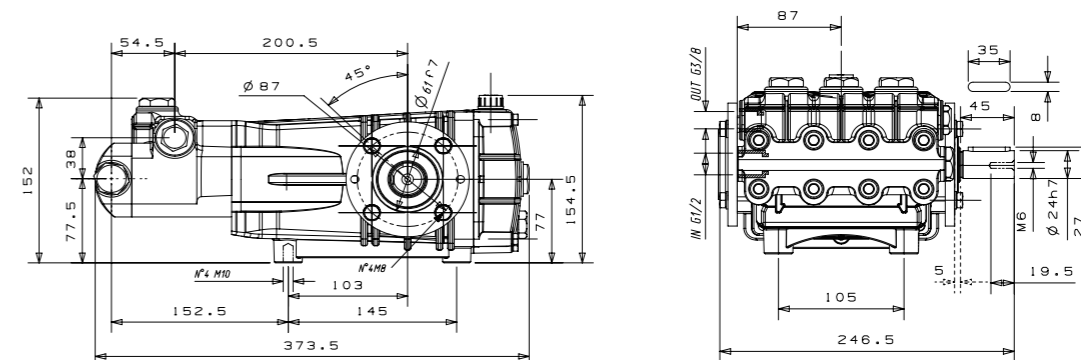

# FCN



实心轴 Ø 24mm

## 产品参数

型号	转速	流量		压力			功率		重量	进水口	出水口
	RPM	L/min	GPM	Bar	Mpa	PSI	kW	HP		KG	Thread
FCN 1550	1450	16.0	4.2	500	50	7250	15.0	21.5	20.5	G 1/2	G 3/8
FCN 1860	1450	18.0	4.8	600	60	8700	22.0	29.0	20.5	G 1/2	G 3/8
FCN 2250	1450	22.0	5.8	500	50	7250	22.0	29.5	20.5	G 1/2	G 3/8
FCN 1850	1750	18.0	5.1	500	50	7250	19.3	25.9	20.5	G 1/2	G 3/8
FCN 2260	1750	22.0	5.7	600	60	8700	26.1	35.0	20.5	G 1/2	G 3/8
FCN 2650	1750	26.0	7.0	500	50	7250	26.6	35.6	20.5	G 1/2	G 3/8

## 尺寸图 (mm)

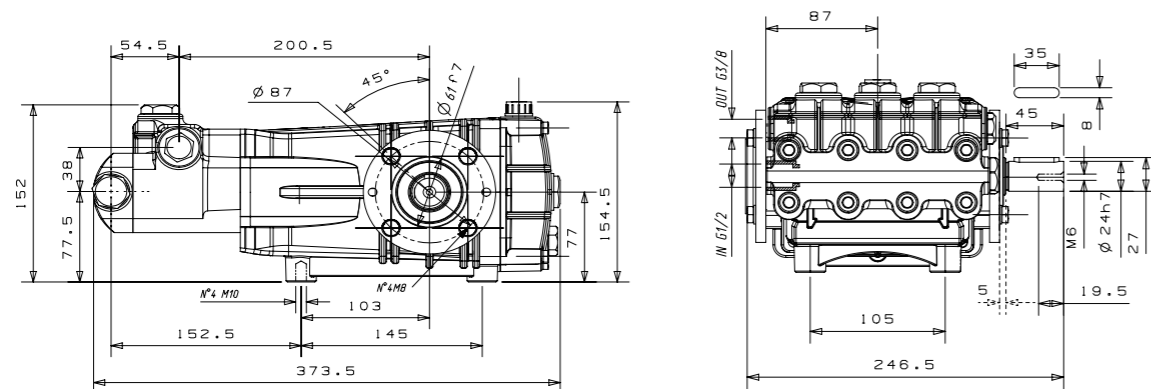

# FCH

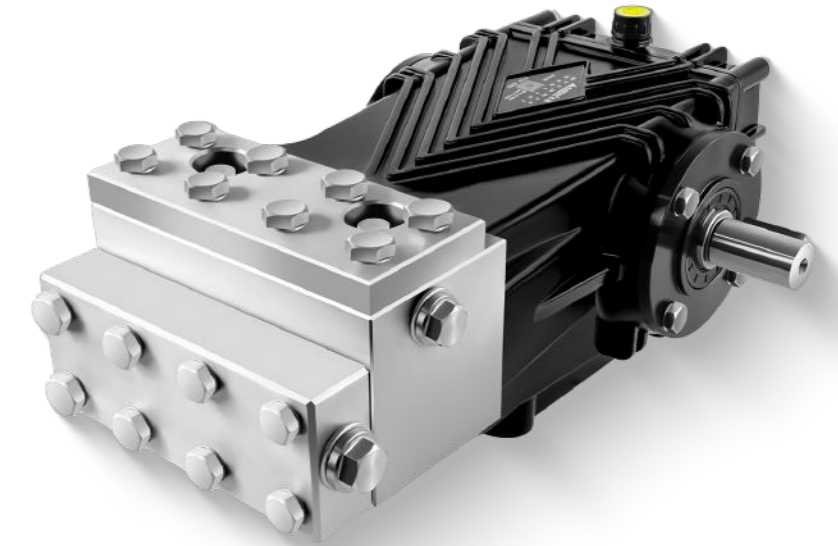

实心轴 Ø 24mm

## 产品参数

型号	转速	流量		压力			功率		重量	进水口	出水口
	RPM	L/min	GPM	Bar	Mpa	PSI	kW	HP		KG	Thread
FCH 1550	1450	15.0	4.2	500	50	7250	15.0	21.5	23.1	G 1/2	G 3/8
FCH 1860	1450	18.0	4.8	600	60	8700	21.6	29.0	23.1	G 1/2	G 3/8
FCH 2250	1450	22.0	5.8	500	50	7250	22.0	29.5	23.1	G 1/2	G 3/8
FCH 1850	1750	18.0	5.1	500	50	7250	19.3	25.9	23.1	G 1/2	G 3/8
FCH 2260	1750	22.6	5.7	600	60	8700	26.1	35.0	23.1	G 1/2	G 3/8
FCH 2650	1750	26.0	7.0	500	50	7250	26.6	35.6	23.1	G 1/2	G 3/8

## 尺寸图 (mm)

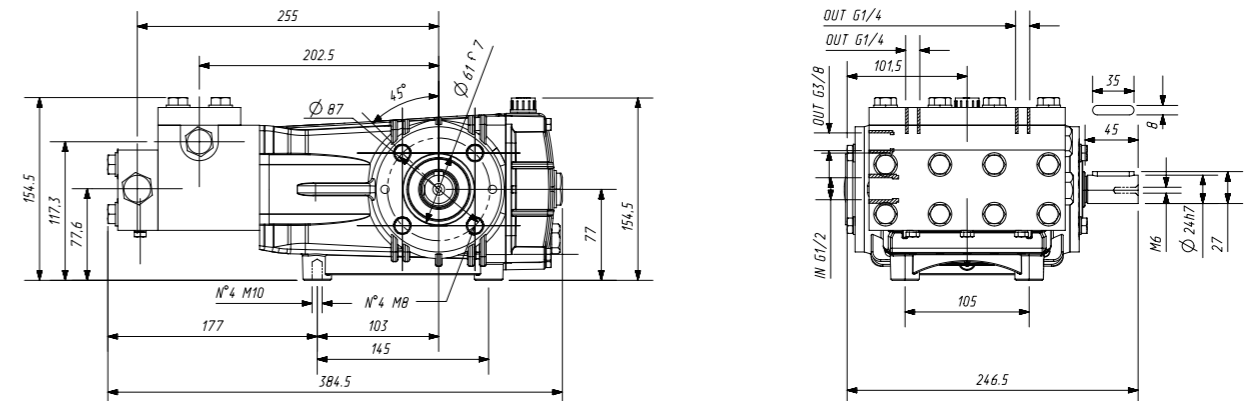

# FCC



实心轴 Ø 24mm

### 产品参数

型号	转速	流量		压力			功率		重量	进水口	出水口
	RPM	L/min	GPM	Bar	Mpa	PSI	kW	HP		KG	Thread
FCC 2135	1450	21.0	5.5	350	35	5075	15.0	19.7	17.5	G 3/4	G 1/2
FCC 3020	1450	30.0	7.9	200	20	2900	12.0	26.8	17.5	G 3/4	G 1/2
FCC 3030	1450	30.0	7.9	300	30	4350	18.0	24.1	17.5	G 3/4	G 1/2
FCC 4025	1450	40.0	10.5	250	25	3525	20.0	28.0	17.5	G 3/4	G 1/2
FCC 5020	1450	50.0	13.2	200	20	2900	20.0	29.0	17.5	G 3/4	G 1/2
FCC 3620	1750	36.0	9.5	200	20	2900	14.4	32.4	17.5	G 3/4	G 1/2
FCC 4819	1750	48.0	12.6	190	19	3625	24.0	33.8	17.5	G 3/4	G 1/2
FCC 6018	1750	60.0	15.8	180	18	2900	24.0	35.0	17.5	G 3/4	G 1/2

### 尺寸图 (mm)

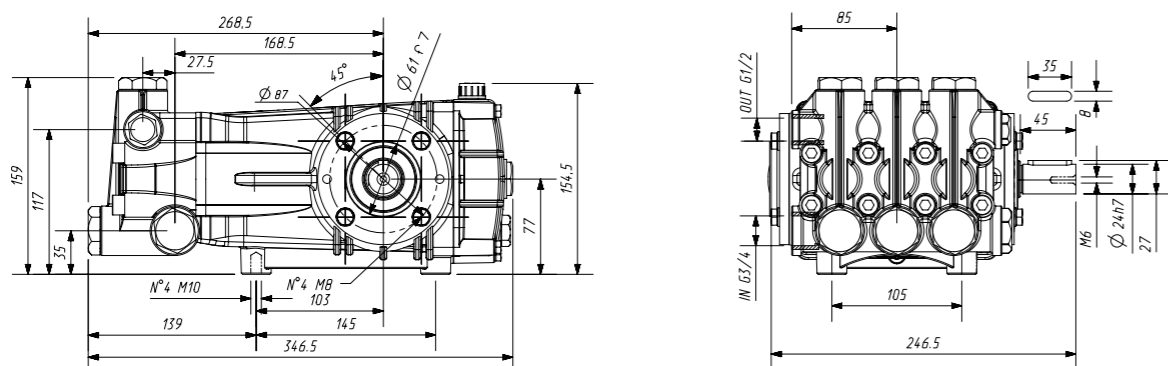

# FCK



实心轴 Ø 24mm

### 产品参数

型号	转速	流量		压力			功率		重量	进水口	出水口
	RPM	L/min	GPM	Bar	Mpa	PSI	kW	HP		KG	Thread
FCK 2135	1450	21.0	5.5	350	35	5075	15.0	19.7	17.5	G 3/4	G 1/2
FCK 3020	1450	30.0	7.9	200	20	2900	12.0	26.8	17.5	G 3/4	G 1/2
FCK 3030	1450	30.0	7.9	300	30	4350	18.0	24.1	17.5	G 3/4	G 1/2
FCK 4025	1450	40.0	10.5	250	25	3525	20.0	28.0	17.5	G 3/4	G 1/2
FCK 5020	1450	50.0	13.2	200	20	2900	20.0	29.0	17.5	G 3/4	G 1/2
FCK 3620	1750	36.0	9.5	200	20	2900	14.4	32.4	17.5	G 3/4	G 1/2
FCK 4819	1750	48.0	12.6	190	19	3625	24.0	33.8	17.5	G 3/4	G 1/2
FCK 6018	1750	60.0	15.8	180	18	2900	24.0	35.0	17.5	G 3/4	G 1/2

### 尺寸图 (mm)

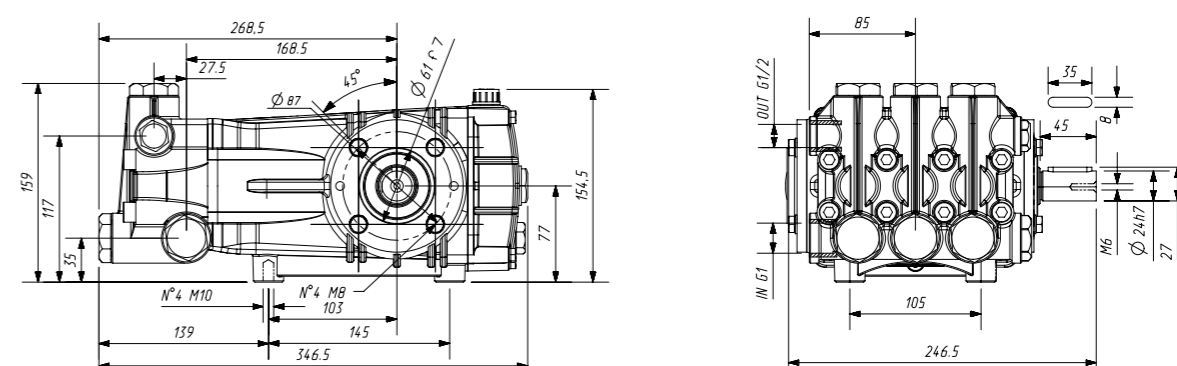

# FCR

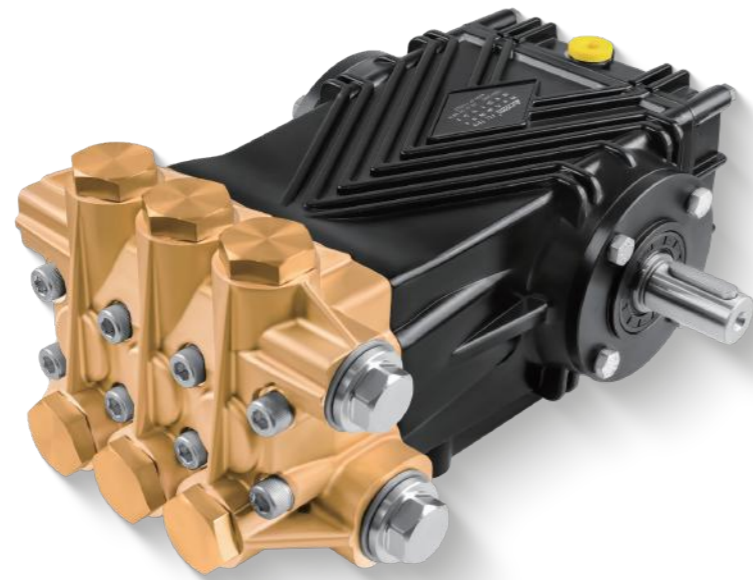

实心轴 Ø 24mm

### 产品参数

型号	转速	流量		压力			功率		重量	进水口	出水口
	RPM	L/min	GPM	Bar	Mpa	PSI	kW	HP		Thread	Thread
FCR 6017	1450	60.0	15.8	170	17	2465	20.4	29.6	19.5	G 1	G 1/2
FCR 7016	1450	70.0	18.5	160	16	2320	22.4	29.1	19.5	G 1	G 1/2
FCR 7217	1750	72.0	19.0	170	17	2465	24.5	35.8	19.5	G 1	G 1/2
FCR 8416	1750	84.0	22.2	160	16	2320	26.8	36.3	19.5	G 1	G 1/2

### 尺寸图 (mm)

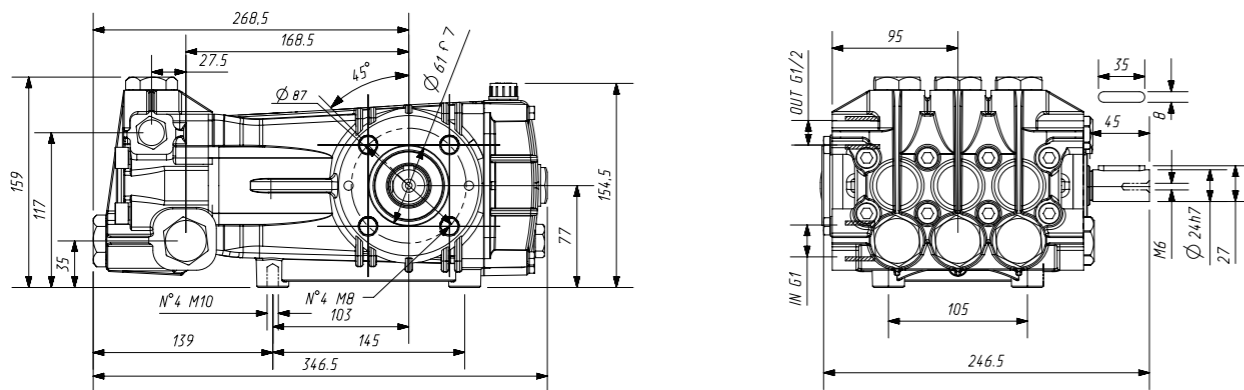

# FCM



实心轴 Ø 24mm

### 产品参数

型号	转速	流量		压力			功率		重量	进水口	出水口
	RPM	L/min	GPM	Bar	Mpa	PSI	kW	HP		Thread	Thread
FCM 6017	1450	60.0	15.8	170	17	2465	20.4	29.6	19.5	G 1	G 1/2
FCM 7016	1450	70.0	18.5	160	16	2320	22.4	29.1	19.5	G 1	G 1/2
FCM 7217	1750	72.0	19.0	170	17	2465	24.5	35.8	19.5	G 1	G 1/2
FCM 8416	1750	84.0	22.2	160	16	2320	26.8	36.3	19.5	G 1	G 1/2

### 尺寸图 (mm)

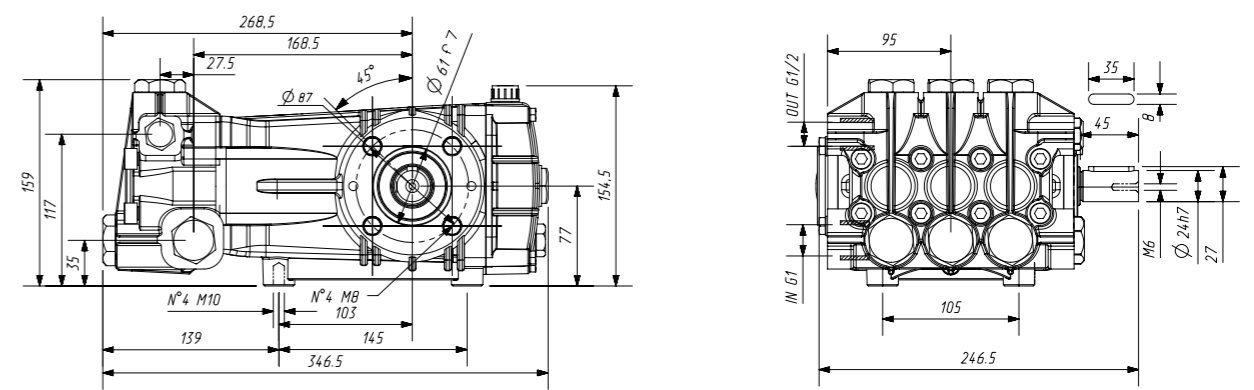

# FCL

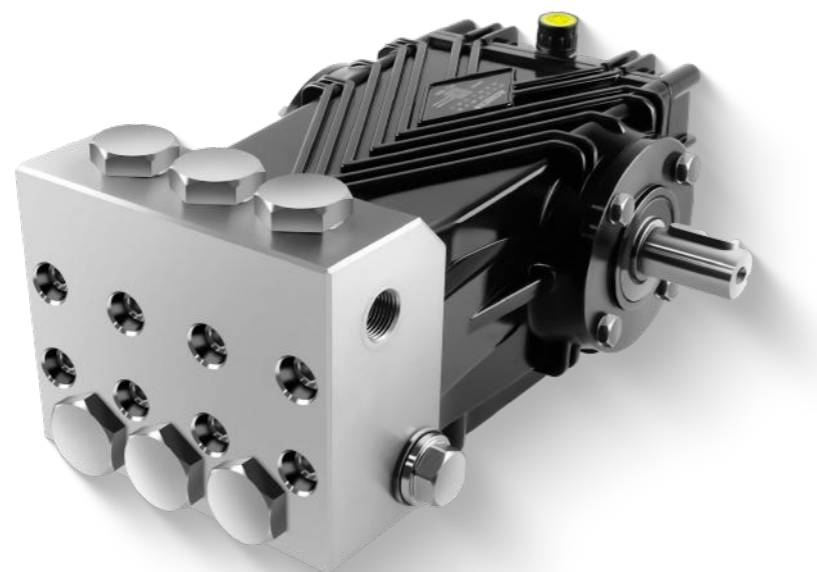

实心轴 Ø 24mm

### 产品参数

型号	流量		压力			功率		重量	进水口	出水口	
	RPM	L/min	GPM	Bar	Mpa	PSI	kW				HP
FCL 3030	1450	30.0	7.9	300	30	4350	18.0	24.1	16.8	G 3/4	G 1/2
FCL 4025	1450	40.0	10.5	250	25	3625	20.0	26.8	16.8	G 3/4	G 1/2
FCL 5020	1450	50.0	13.2	200	20	2900	20.0	26.8	16.8	G 3/4	G 1/2
FCL 6018	1450	60.0	15.9	180	18	2610	21.6	29.0	16.8	G 3/4	G 1/2
FCL 3630	1750	36.2	9.6	300	30	4350	21.7	29.1	16.8	G 3/4	G 1/2
FCL 4825	1750	48.0	12.7	250	25	3625	24.0	32.1	16.8	G 3/4	G 1/2
FCL 6020	1750	60.3	15.9	200	19	2755	24.0	32.1	16.8	G 3/4	G 1/2
FCL 7218	1750	72.4	19.1	180	18	2610	26.1	35.0	16.8	G 3/4	G 1/2

### 尺寸图 (mm)

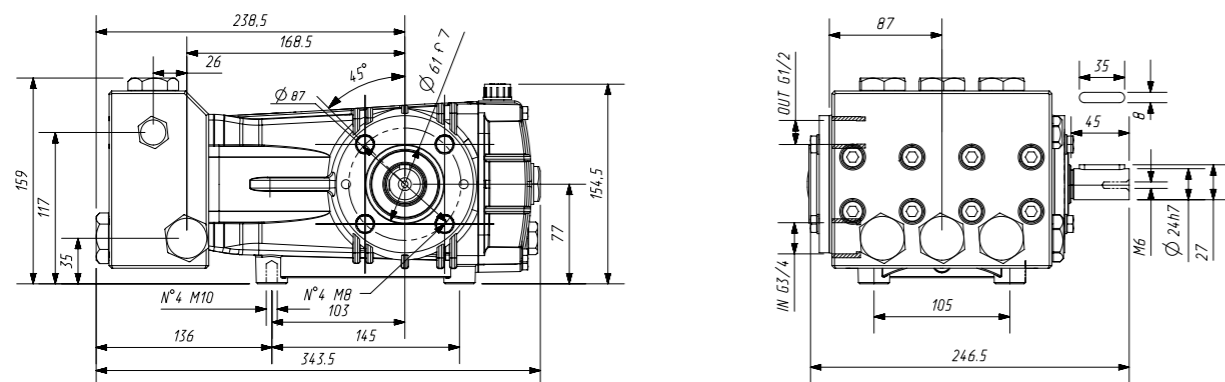

# FDH

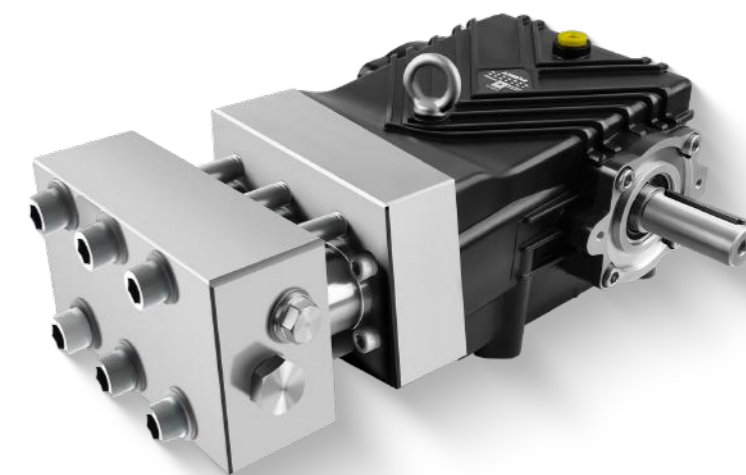

实心轴 Ø 30mm

### 产品参数

型号	流量		压力			功率		重量	进水口	出水口	
	RPM	L/min	GPM	Bar	Mpa	PSI	kW				HP
FDH 6200	750	6.7	1.8	2000	200	29000	25.6	34.4	42.0	G 1/2	G 1/2
FDH 15100	1450	15.0	4.0	1000	100	14500	28.8	38.7	42.0	G 1/2	G 1/2
FDH 1880	1450	18.0	4.8	800	80	11600	27.7	37.1	42.0	G 1/2	G 1/2
FDH 18100	1750	18.0	4.2	1000	100	14500	30.8	41.3	42.0	G 1/2	G 1/2
FDH 2080	1750	20.0	5.3	800	80	11600	30.8	41.3	42.0	G 1/2	G 1/2

### 尺寸图 (mm)

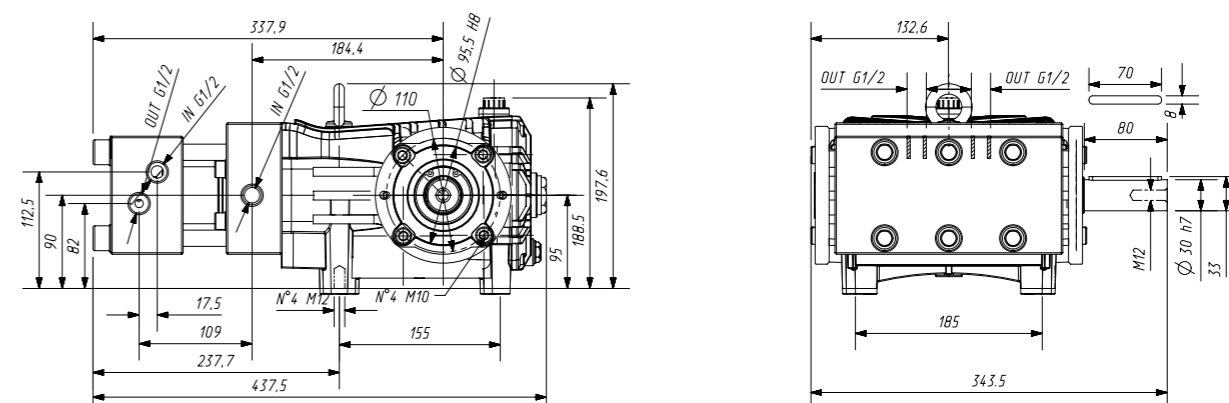

# FDK

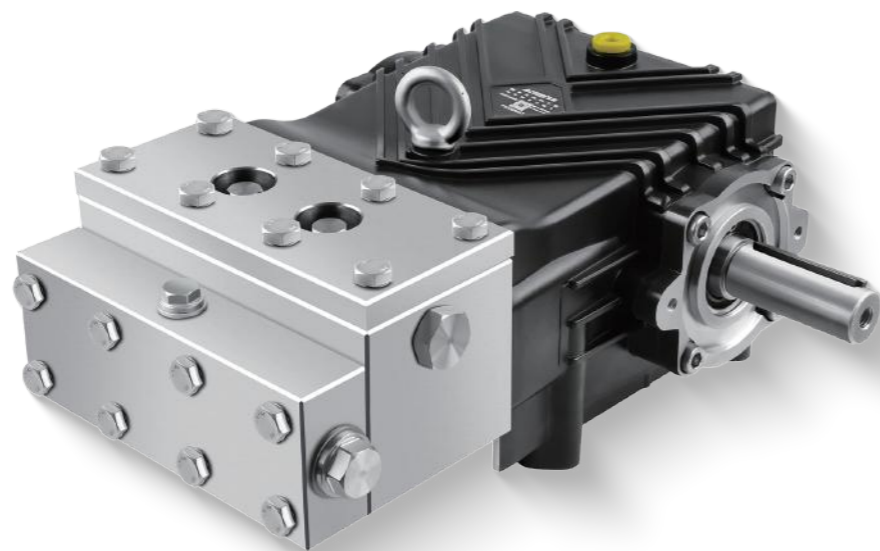

实心轴 Ø 30mm

### 产品参数

型号	转速		流量		压力			功率		重量	接口	
	RPM	L/min	GPM	Bar	Mpa	PSI	kW	HP	Thread		Thread	
FDK 3050	1450	30.0	7.9	500	50	7250	30.0	40.2	38.5	G 3/4	G 1/2	
FDK 4035	1450	40.0	10.5	350	35	5075	28.0	37.5	38.5	G 3/4	G 1/2	
FDK 5030	1450	50.0	13.2	300	30	4350	30.0	40.2	38.5	G 3/4	G 1/2	
FDK 5525	1450	55.0	14.5	250	25	3625	27.5	36.8	38.5	G 3/4	G 1/2	
FDK 3650	1750	36.0	9.5	500	50	7250	36.0	48.2	38.5	G 3/4	G 1/2	
FDK 4835	1750	48.0	12.6	350	35	5075	33.5	45.0	38.5	G 3/4	G 1/2	
FDK 6030	1750	60.0	15.8	300	30	4350	36.0	48.2	38.5	G 3/4	G 1/2	
FDK 6625	1750	66.0	17.4	250	25	3625	33.0	44.2	38.5	G 3/4	G 1/2	

### 尺寸图 (mm)

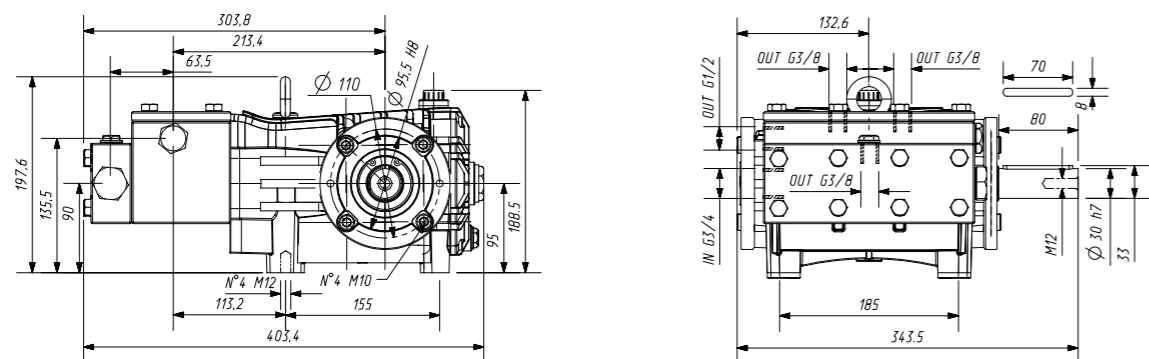

# FDL

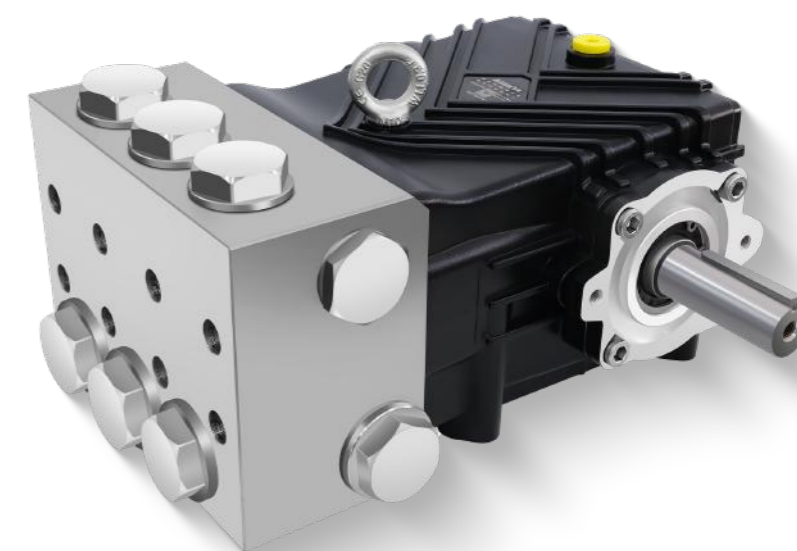

实心轴 Ø 30mm

### 产品参数

型号	转速		流量		压力			功率		重量	接口	
	RPM	L/min	GPM	Bar	Mpa	PSI	kW	HP	Thread		Thread	
FDL 10015	1450	100.0	26.4	150	15	2175	28.8	38.7	39.5	G 1"1/4	G 1"	
FDL 12013	1450	120.0	31.7	130	13	1885	30.0	40.2	39.5	G 1"1/4	G 1"	
FDL 15010	1450	150.0	39.6	100	10	1450	28.8	38.7	39.5	G 1"1/4	G 1"	
FDL 6915	1000	69.0	18.2	150	15	2175	19.9	26.7	39.5	G 1"1/4	G 1"	
FDL 8213	1000	82.8	21.9	130	13	1885	20.7	27.7	39.5	G 1"1/4	G 1"	
FDL 10310	1000	103.0	27.3	100	10	1411	19.9	26.7	39.5	G 1"1/4	G 1"	

### 尺寸图 (mm)

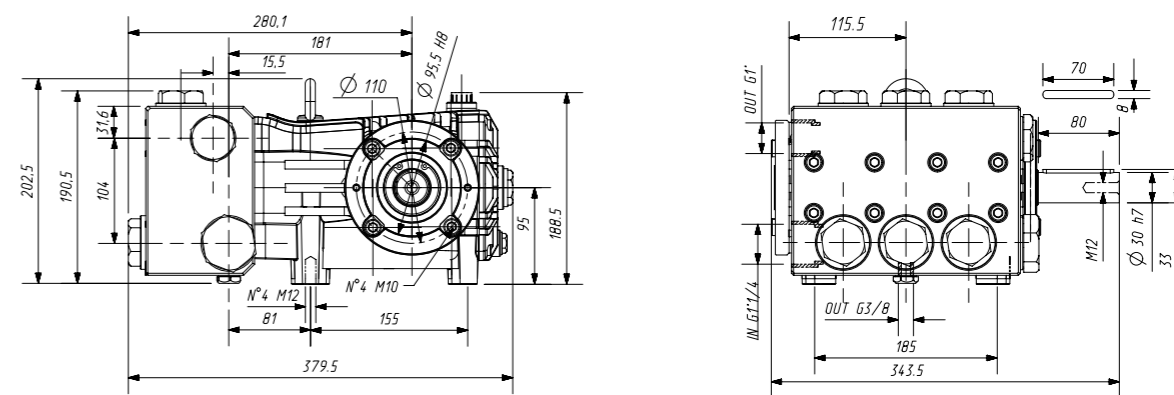

# FEH

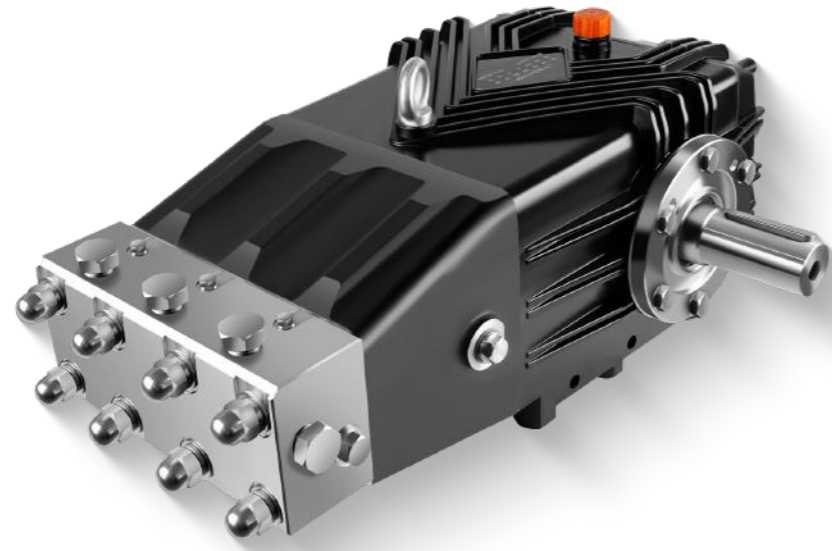

实心轴 Ø 40mm

### 产品参数

型号	转速	流量		压力			功率		重量	进水口	出水口
	RPM	L/min	GPM	Bar	Mpa	PSI	kW	HP		KG	Thread
FEH 20100	1000	20.0	5.3	1000	100	14500	38.5	51.6	65.5	G 1/2	G 1/2
FEH 20120	1000	20.0	5.3	1200	120	17400	46.2	61.9	65.5	G 1/2	G 1/2
FEH 25100	1000	25.0	6.6	1000	100	14500	48.1	64.5	65.5	G 1/2	G 1/2
FEH 2580	1000	25.0	6.6	800	80	11600	38.5	51.6	65.5	G 1/2	G 1/2

### 尺寸图 (mm)

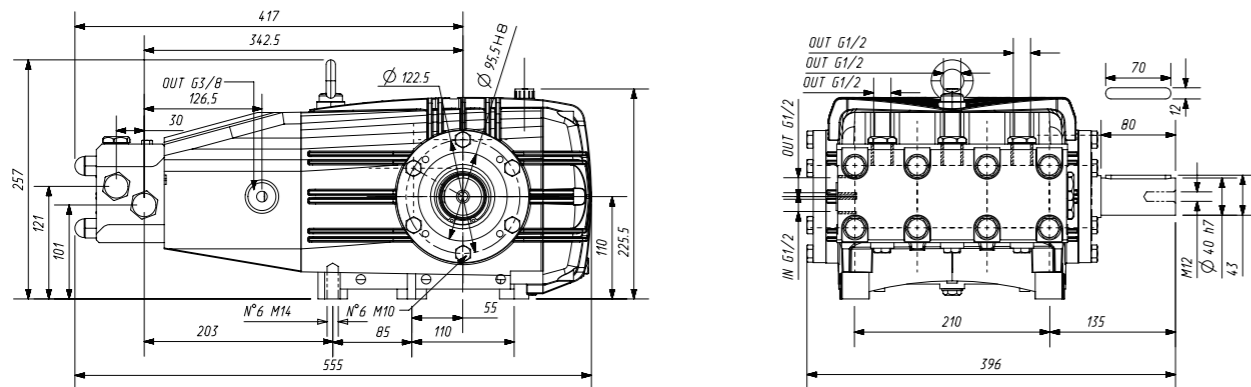

# FES

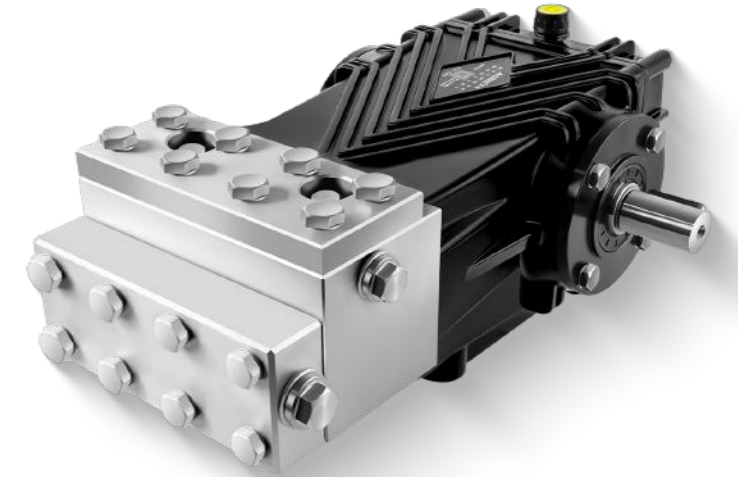

实心轴 Ø 40mm

### 产品参数

型号	转速	流量		压力			功率		重量	进水口	出水口
	RPM	L/min	GPM	Bar	Mpa	PSI	kW	HP		KG	Thread
FES 15150	800	15	3.9	1500	150	21755	45.0	60.0	79.0	G 1/2	G 1/2
FES 10200	800	10	2.6	2000	200	29000	40.0	53.6	79.0	G 1/2	G 1/2

### 尺寸图 (mm)

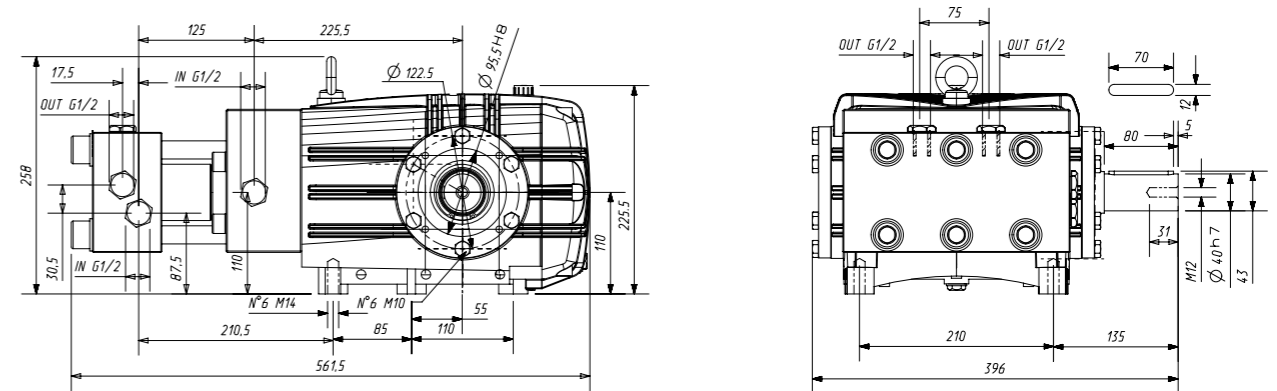

# FEK



实心轴 Ø 40mm

### 产品参数

型号	转速	流量		压力			功率		重量	进水口	出水口
	RPM	L/min	GPM	Bar	Mpa	PSI	kW	HP		KG	Thread
FEK 3075	1000	30.0	7.9	750	75	10875	43.3	58.0	68.0	G 1"	G 1/2
FEK 3665	1000	36.0	9.5	650	65	9425	45.0	60.3	68.0	G 1"	G 1/2
FEK 4060	1000	40.0	10.6	600	60	8700	46.2	61.9	68.0	G 1"	G 1/2
FEK 4850	1000	48.0	12.7	500	50	7250	46.2	61.9	68.0	G 1"	G 1/2
FEK 5045	1000	50.0	13.2	450	45	6525	43.3	58.0	68.0	G 1"	G 1/2

### 尺寸图 (mm)

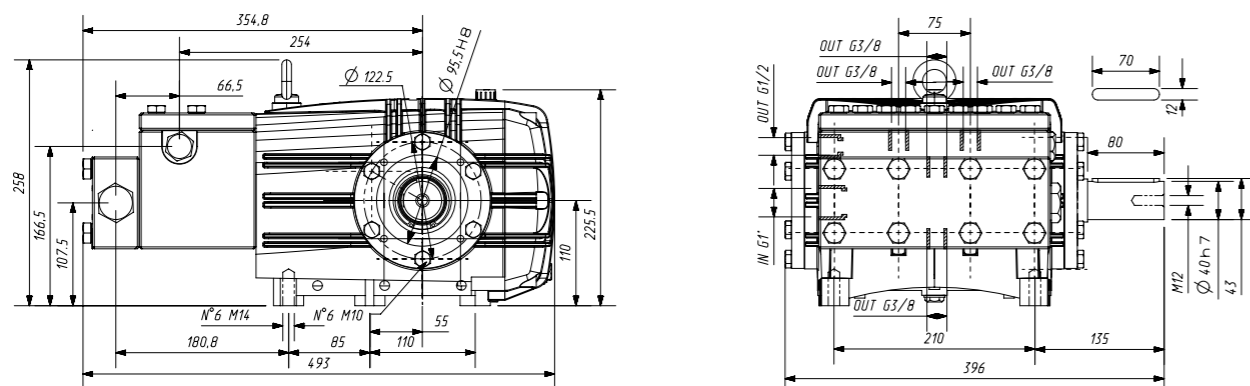

# FEL

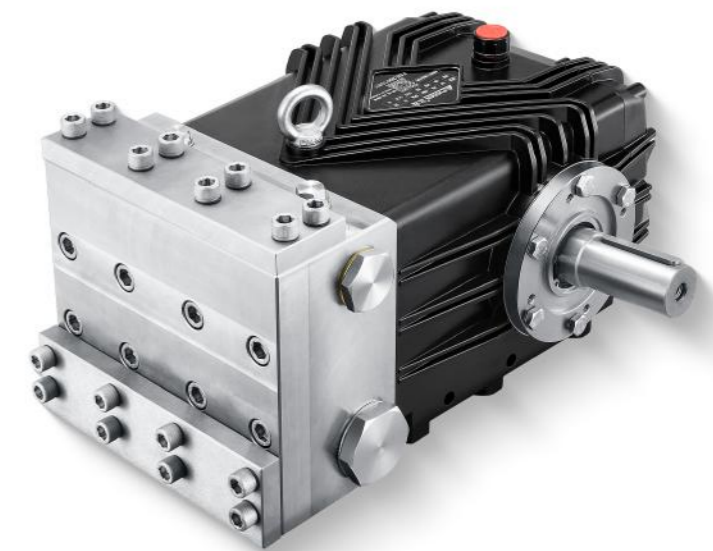

实心轴 Ø 40mm

### 产品参数

型号	转速	流量		压力			功率		重量	进水口	出水口
	RPM	L/min	GPM	Bar	Mpa	PSI	kW	HP		KG	Thread
FEL 7535	1000	75.0	19.8	350	35	5075	50.5	67.7	70.5	G 1 1/2	G 1"
FEL 10020	1000	100.0	26.4	200	20	2900	38.5	51.6	70.5	G 1 1/2	G 1"
FEL 13022	1000	130.0	34.3	220	22	3190	55.0	73.8	70.5	G 1 1/2	G 1"
FEL 16018	1000	160.0	42.3	180	18	2610	55.4	74.3	70.5	G 1 1/2	G 1"
FEL 20010	1000	200.0	52.8	100	10	1450	38.5	51.6	70.5	G 1 1/2	G 1"
FEL 21516	1000	215.0	56.8	160	16	2320	66.2	88.7	70.5	G 1 1/2	G 1"

### 尺寸图 (mm)

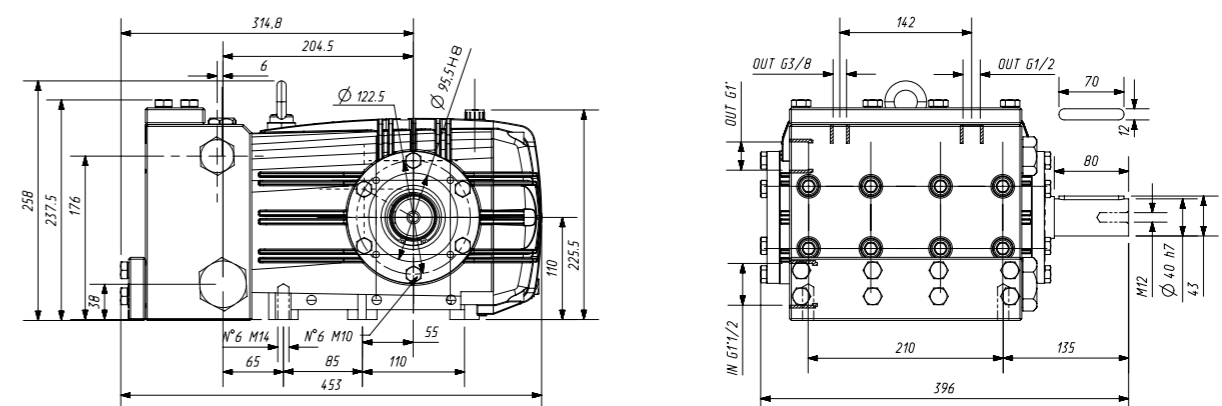

# FEK-G



实心轴 Ø 40mm

### 产品参数

型号	转速		流量		压力			功率		重量	进水口		出水口	
	RPM	L/min	GPM	Bar	Mpa	PSI	kW	HP	KG		Thread	Thread		
FEK-G 3075	1000	30.0	7.9	750	75	10875	43.3	58.0	68.0	G 1"	G 1/2			
FEK-G 3665	1000	36.0	9.5	650	65	9425	45.0	60.3	68.0	G 1"	G 1/2			
FEK-G 4060	1000	40.0	10.6	600	60	8700	46.2	61.9	68.0	G 1"	G 1/2			
FEK-G 4850	1000	48.0	12.7	500	50	7250	46.2	61.9	68.0	G 1"	G 1/2			
FEK-G 5045	1000	50.0	13.2	450	45	6525	43.3	58.0	68.0	G 1"	G 1/2			
FEK-G 2275	750	22.5	5.9	750	75	10875	32.5	43.5	68.0	G 1"	G 1/2			
FEK-G 2765	750	27.0	7.1	650	65	9425	33.8	45.3	68.0	G 1"	G 1/2			
FEK-G 3060	750	30.0	7.9	600	60	8700	34.6	46.4	68.0	G 1"	G 1/2			
FEK-G 3650	750	36.0	9.5	500	50	7250	34.6	46.4	68.0	G 1"	G 1/2			
FEK-G 3745	750	37.5	9.9	450	45	6525	32.5	43.5	68.0	G 1"	G 1/2			

### 尺寸图 (mm)

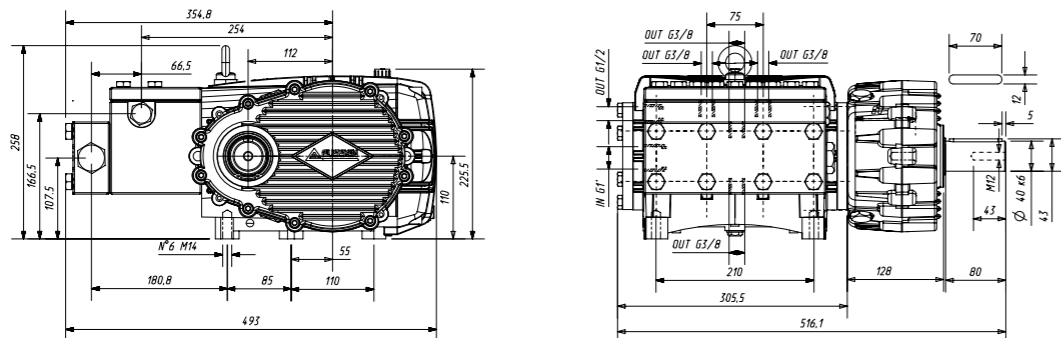

# FES-G

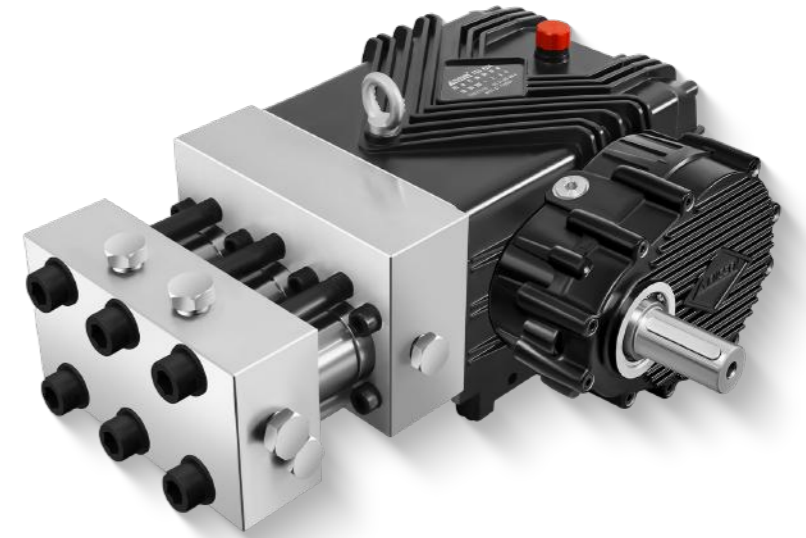

实心轴 Ø 40mm

### 产品参数

型号	转速		流量		压力			功率		重量	进水口		出水口	
	RPM	L/min	GPM	Bar	Mpa	PSI	kW	HP	KG		Thread	Thread		
FES-G 15150	800	15	3.9	1500	150	21755	45.0	60.0	79.0	G 1/2	G 1/2			
FES-G 10200	800	10	2.6	2000	200	29000	40.0	53.6	79.0	G 1/2	G 1/2			

### 尺寸图 (mm)

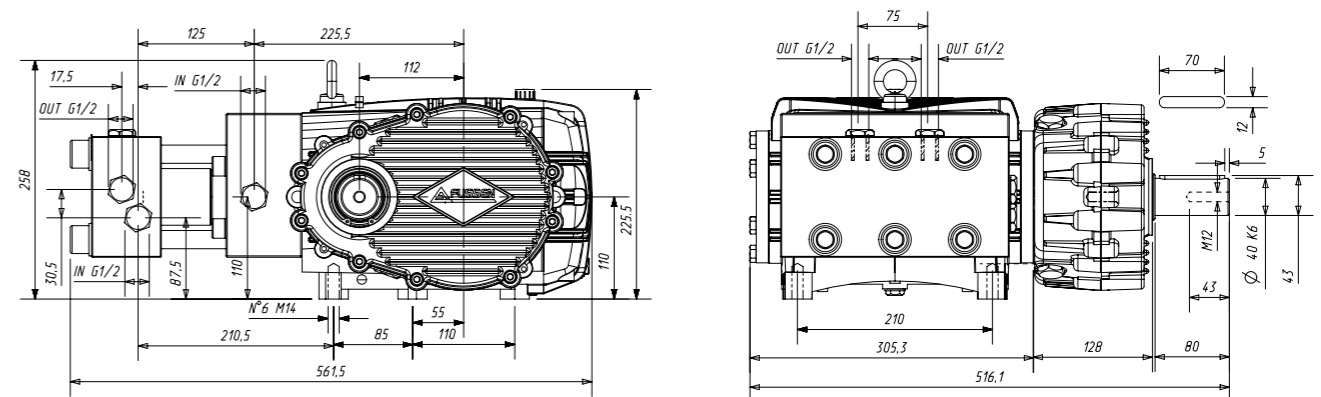





型号	流量		压力		温度	进水口	出水口	旁通管
	L/min	gpm	bar	psi	°C	thread	thread	thread
FVK25-P	30	7.9	250	3625	80	G3/8	G3/8 G1/2	/



型号	流量		压力		温度	进水口	出水口	旁通管
	L/min	gpm	bar	psi	°C	thread	thread	thread
FVE25-P	30	7.9	250	3625	80	G3/8	G3/8 G1/2	G1/4



型号	流量		压力		温度	进水口	出水口	旁通管
	L/min	gpm	bar	psi	°C	thread	thread	thread
FVK25	30	7.9	250	3625	80	G3/8	G3/8 G1/2	/



型号	流量		压力		温度	进水口	出水口	旁通管
	L/min	gpm	bar	psi	°C	thread	thread	thread
FVE25	30	7.9	250	3625	80	G3/8	G3/8 G1/2	G1/4



型号	流量		压力		温度	进水口	出水口	旁通管
	L/min	gpm	bar	psi	°C	thread	thread	thread
FV30	40	22.5	300	4350	90	G3/8	G1/2	G1/2



型号	流量		压力		温度	进水口	出水口	旁通管
	L/min	gpm	bar	psi	°C	thread	thread	thread
FV35	40	10.6	350	5075	90	G3/8	G3/8	G1/2



型号	流量		压力		温度	进水口	出水口	旁通管
	L/min	gpm	bar	psi	°C	thread	thread	thread
FV50	80	21.1	500	8700	90	G1/2	G1/2	G1/2



型号	流量		压力		温度	进水口	出水口	旁通管
	L/min	gpm	bar	psi	°C	thread	thread	thread
FV90	60	15.8	900	13050	60	G1/2	G1/2	G1/2



型号	流量		压力		温度	进水口	出水口	旁通管
	L/min	gpm	bar	psi	°C	thread	thread	thread
FV150	30	10.6	1000	14500	60	G3/8	G3/8	G3/8



型号	流量		压力		温度	进水口	出水口	旁通管
	L/min	gpm	bar	psi	°C	thread	thread	thread
FVF32	80	21.1	320	4640	90	G1/2	G1/2	G1/2



型号	流量		压力		温度	进水口	出水口	旁通管
	L/min	gpm	bar	psi	°C	thread	thread	thread
FV60	80	21.1	600	8700	90	G1/2	G1/2	G1/2



型号	流量		压力		温度	进水口	出水口	旁通管
	L/min	gpm	bar	psi	°C	thread	thread	thread
FV80	80	21.1	800	11600	90	G1/2	G1/2	G1/2



型号	流量		压力		温度	进水口	出水口	旁通管
	L/min	gpm	bar	psi	°C	thread	thread	thread
FV20	200	52.8	150	2175	90	G1	G1	G1



型号	流量		压力		温度	进水口	出水口	旁通管
	L/min	gpm	bar	psi	°C	thread	thread	thread
FV20S	200	52.8	150	2175	90	G1	G1	G1



型号	流量		压力		温度	进水口	出水口	旁通管
	L/min	gpm	bar	psi	°C	thread	thread	thread
FS20	200	52.8	200	2900	80	G3/4	/	G1/2



型号	流量		压力		温度	进水口	出水口	旁通管
	L/min	gpm	bar	psi	°C	thread	thread	thread
FS30	500	132	300	4350	80	G1	/	G1



型号	流量		压力		温度	进水口	出水口	旁通管
	L/min	gpm	bar	psi	°C	thread	thread	thread
FS70	80	21.1	700	10150	80	G3/8 G1/2	/	/



型号	流量		压力		温度	进水口	出水口	旁通管
	L/min	gpm	bar	psi	°C	thread	thread	thread
FS80	80	21.1	800	11600	80	G3/8	/	G1/2



型号	流量		压力		温度	进水口	出水口	旁通管
	L/min	gpm	bar	psi	°C	thread	thread	thread
FS150	30	7.8	1500	21750	80	G3/8	/	G3/8



型号	流量		压力		温度	进水口	出水口	旁通管
	L/min	gpm	bar	psi	°C	thread	thread	thread
FSF15	40	10.6	200	2900	80	G3/8	/	G3/8

喷嘴 型号	压力																			
	Bar	20	30	40	50	60	70	80	90	100	110	120	130	140	150	160	170	180	190	200
	PSI	290	435	580	725	870	1015	1160	1305	1450	1595	1740	1885	2030	2175	2320	2465	2610	2755	2900
	Ø mm	流量 (L/min)																		
015	0.80	1.5	1.9	2.2	2.4	2.6	2.8	3	3.2	3.4	3.6	3.7	3.9	4.0	4.2	4.3	4.4	4.6	4.7	4.8
02	0.91	2.1	2.5	2.9	3.3	3.6	3.8	4.1	4.4	4.6	4.8	5.0	5.2	5.4	5.6	5.8	6.0	6.2	6.3	6.5
025	1.00	2.5	3.1	3.5	4.0	4.3	4.7	5.0	5.3	5.6	5.9	6.1	6.4	6.6	6.9	7.1	7.3	7.5	7.7	7.9
03	1.09	3.0	3.7	4.3	4.8	5.3	5.7	6.1	6.5	6.8	7.1	7.4	7.8	8.0	8.3	8.6	8.9	9.1	9.4	9.6
035	1.15	3.6	4.4	5.1	5.7	6.2	6.7	7.2	7.6	8.0	8.4	8.8	9.1	9.5	9.8	10.1	10.4	10.7	11.0	11.3
04	1.19	4.1	5.0	5.8	6.4	7.0	7.6	8.1	8.6	9.1	9.5	10	10.4	10.8	11.1	11.5	11.9	12.2	12.5	12.9
045	1.27	4.6	5.6	6.5	7.3	8.0	8.6	9.2	9.8	10.3	10.8	11.3	11.7	12.2	12.6	13	13.4	13.8	14.2	14.6
05	1.35	5.1	6.2	7.2	8.1	8.8	9.5	10.2	10.8	11.4	12.0	12.5	13.0	13.5	14.0	14.4	14.9	15.3	15.7	16.1
055	1.40	5.6	6.8	7.9	8.8	9.7	10.5	11.2	11.9	12.5	13.1	13.7	14.3	14.8	15.3	15.8	16.3	16.8	17.2	17.7
06	1.47	6.1	7.5	8.7	9.7	10.6	11.5	12.3	13.0	13.7	14.4	15.0	15.6	16.2	16.8	17.3	17.9	18.4	18.9	19.4
065	1.52	6.6	8.1	9.4	10.5	11.5	12.4	13.2	14.0	14.8	15.5	16.2	16.9	17.5	18.1	18.7	19.3	19.9	20.4	20.9
07	1.60	7.2	8.8	10.1	11.3	12.4	13.4	14.3	15.2	16.0	16.8	17.5	18.2	18.9	19.6	20.2	20.9	21.5	22.1	22.6
075	1.65	7.6	9.4	10.8	12.1	13.2	14.3	15.3	16.2	17.1	17.9	18.7	19.5	20.2	20.9	21.6	22.3	22.9	23.6	24.2
08	1.70	8.1	10.0	11.5	12.9	14.1	15.2	16.3	17.3	18.2	19.1	19.9	20.8	21.5	22.3	23.0	23.7	24.4	25.1	25.7
085	1.75	8.7	10.6	12.3	13.7	15.0	16.2	17.4	18.4	19.4	20.3	21.3	22.1	23.0	23.8	24.5	25.3	26.0	26.7	27.4
09	1.80	9.4	11.5	13.3	14.8	16.3	17.6	18.8	19.9	21.0	22.0	23.0	23.9	24.8	25.7	26.6	27.4	28.2	28.9	29.7
095	1.85	9.8	12.0	13.9	15.6	17.0	18.4	19.7	20.9	22.0	23.1	24.1	25.1	26.0	26.9	27.8	28.7	29.5	30.3	31.1
10	1.90	10.3	12.6	14.5	16.3	17.8	19.2	20.6	21.8	23.0	24.1	25.2	26.2	27.2	28.2	29.1	30.0	30.9	31.7	32.5
105	1.94	10.7	13.2	16.6	18.2	18.6	19.9	20.1	22.8	23.5	25.2	25.7	27.4	28.4	28.8	30.4	30.6	32.2	33.1	33.2
11	1.98	11.2	13.7	15.8	17.7	19.4	20.9	22.4	23.7	25.0	26.2	27.4	28.5	29.6	30.6	31.6	32.6	33.5	34.5	35.4
115	2.03	11.6	14.2	16.4	18.4	20.1	21.8	23.3	24.7	26.0	27.3	28.5	29.6	30.8	31.8	32.9	33.9	34.9	35.8	36.8
12	2.08	12.1	14.8	17.1	19.1	20.9	22.6	24.1	25.6	27.0	28.3	29.6	30.8	31.9	33.1	34.2	35.2	36.2	37.2	38.2
125	2.13	12.5	15.3	17.7	19.8	21.7	23.4	25.0	26.6	28.0	29.4	30.7	31.9	33.1	34.3	35.4	36.5	37.6	38.6	39.6
13	2.16	13.4	16.4	19.0	21.2	23.2	25.1	26.8	28.5	30.0	31.5	32.9	34.2	35.5	36.7	37.9	39.1	40.2	41.4	42.4
14	2.26	14.3	17.5	20.2	22.6	24.8	26.8	28.6	30.4	32.0	33.6	35.1	36.5	37.9	39.2	40.5	41.7	42.9	44.1	45.3
15	2.34	15.2	18.6	21.5	24.0	26.3	28.4	30.4	32.3	34.0	35.7	37.2	38.8	40.2	41.6	43.0	44.3	45.6	46.9	48.1
16	2.41	16.1	19.7	22.8	25.5	27.9	30.1	32.2	34.2	36.0	37.8	39.4	41.0	42.6	44.1	45.5	46.9	48.3	49.6	50.9
18	2.54	18.3	22.5	25.9	29.0	31.8	34.3	36.7	38.9	41.0	43.0	44.9	46.7	48.5	50.2	51.9	53.5	55.0	56.5	58.0
20	2.69	20.6	25.2	29.1	32.5	35.6	38.5	41.1	43.6	46.0	48.2	50.4	52.4	54.4	56.3	58.2	60.0	61.7	63.4	65.1
25	3.00	25.5	31.2	36.0	40.3	44.2	47.7	51.0	54.1	57.0	59.8	62.4	65.0	67.4	69.8	72.1	74.3	76.5	78.6	80.6
30	3.30	30.4	37.2	43.0	48.1	52.7	56.9	60.8	64.5	68.0	71.3	74.5	77.5	80.5	83.3	86.0	88.7	91.2	93.7	96.2
40	3.80	40.7	49.8	57.6	64.3	70.5	76.1	81.4	86.3	91.0	95.4	99.7	103.8	107.7	111.5	115.1	118.6	122.1	125.4	128.7
50	4.20	51.0	62.4	72.1	80.6	88.3	95.4	102.0	108.1	114.0	119.6	124.9	130.0	134.9	139.6	144.2	148.6	152.9	157.1	161.2
60	4.70	61.3	75.0	86.6	96.9	106.1	114.6	122.5	130.0	137.0	143.7	150.1	156.2	162.1	167.8	173.3	178.6	183.8	188.8	193.7
70	5.10	71.6	87.6	101.2	113.1	123.9	133.9	143.1	151.8	160.0	167.8	175.3	182.4	189.3	196.0	202.4	208.6	214.7	220.5	226.3
80	5.50	81.4	99.7	115.1	128.7	141.0	152.3	162.8	172.7	182.0	190.9	199.4	207.5	215.3	222.9	230.2	237.3	244.2	250.9	257.4
90	5.90	91.7	112.3	129.7	145.0	158.8	171.5	183.4	194.5	205.0	215.0	224.6	233.7	242.6	251.1	259.3	267.3	275	282.6	289.9

喷嘴 型号	压力																			
	Bar	210	220	230	240	250	280	300	350	400	450	500	550	600	700	800	900	1000	1100	1250
	PSI	3045	3190	3335	3480	3625	4060	4350	5075	5800	6525	7250	7975	8700	10150	11600	13050	14500	15955	18130
	Ø mm	流量 (L/min)																		
015	0.80	4.9	5.0	5.2	5.3	5.4	5.7	5.9	6.4	6.8	7.2	7.6	8.0	8.3	8.9	9.5	10.1	10.6	11.1	11.9
02	0.91	6.7	6.8	7.0	7.1	7.3	7.7	8.0	8.6	9.2	9.8	10.3	10.8	11.3	11.8	12.6	13.4	14.1	14.8	15.8
025	1.00	8.1	8.3	8.5	8.7	8.9	9.4	9.7	10.5	11.2	11.9	12.5	13.1	13.7	14.8	15.8	16.8	17.7	18.5	19.8
03	1.09	9.9	10.1	10.3	10.5	10.8	11.4	11.8	12.7	13.6	14.4	15.2	15.9	16.7	17.7	19.0	20.1	21.2	22.2	23.7
035	1.15	11.6	11.9	12.1	12.4	12.6	13.4	13.9	15.0	16.0	17.0	17.9	18.8	19.6	20.7	22.1	23.5	24.7	26.0	27.7
04	1.19	13.2	13.5	13.8	14.1	14.4	15.2	15.8	17.0	18.2	19.3	20.3	21.3	22.3	23.7	25.3	26.8	28.3	29.7	31.6
045	1.27	14.9	15.3	15.6	16.0	16.3	17.2	17.8	19.3	20.6	21.8	23.0	24.2	25.2	26.6	28.5	30.2	31.8	33.4	35.6
05	1.35	16.5	16.9	17.3	17.7	18.0	19.1	19.7	21.3	22.8	24.2	25.5	26.7	27.9	29.6	31.6	33.5	35.4	37.1	39.5
055	1.40	18.1	18.5	19.0	19.4	19.8	20.9	21.7	23.4	25.0	26.5	28.0	29.3	30.6	32.5	34.8	36.9	38.9	40.8	43.5
06	1.47	19.9	20.3	20.8	21.2	21.7	22.9	23.7	25.6	27.4	29.1	30.6	32.1	33.6	35.5	37.9	40.2	42.4	44.5	47.4
065	1.52	21.4	22.0	22.4	22.9	23.4	24.8	25.6	27.7	29.6	31.4	33.1	34.7	36.3	38.5	41.1	43.6	46.0	48.2	51.4
07	1.60	23.2	23.7	24.3	24.8	25.3	26.8	27.7	29.9	32.0	33.9	35.8	37.5	39.2	41.4	44.3	47.0	49.5	51.9	55.3
075	1.65	24.8	25.4	25.9	26.5	27.0	28.6	29.6	32.0	34.2	36.3	38.2	40.1	41.9	44.4	47.4	50.3	53.0	55.6	59.3
08	1.70	26.4	27.0	27.6	28.2	28.8	30.5	31.5	34.0	36.4	38.6	40.7	42.7	44.6	47.3	50.6	53.7	56.6	59.3	63.2
085	1.75	28.1	28.8	29.4	30.1	30.7	32.5	33.6	36.3	38.8	41.2	43.4	45.5	47.5	50.3	53.8	57.0	60.1	63.0	67.2
09	1.80	30.4	31.1	31.8	32.5	33.2	35.1	36.4	39.3	42.0	44.5	47.0	49.2	51.4	53.2	56.9	60.4	63.6	66.7	71.2
095	1.85	31.9	32.6	33.4	34.1	34.8	36.8	38.1	41.2	44.0	46.7	49.2	51.6	53.9	56.2	60.1	63.7	67.2	70.5	75.1
10	1.90	33.3	34.1	34.9	35.6	36.4	38.5	39.8	43.0	46.0	48.8	51.4	53.9	56.3	59.2	63.2	67.1	70.7	74.2	79.1
105	1.94	34.8	34.8	36.4	37.2	37.1	39.3	40.7	43.9	47.0	51.0	52.5	56.3	57.5	62.1	66.4	70.4	74.2	79.7	84.9
11	1.98	36.2	37.1	37.9	38.7	39.5	41.8	43.3	46.8	50.0	53.0	55.9	58.6	61.2	65.1	69.6	73.8	77.8	81.6	87.0
115	2.03	37.7	38.6	39.4	40.3	41.1	43.5	45.0	48.6	52.0	55.2	58.1	61.0	63.7	68.0	72.7	77.1	81.3	85.3	90.9
12	2.08	39.1	40.0	40.9	41.8	42.7	45.2	46.8	50.5	54.0	57.3	60.4	63.3	66.1	71.0	75.9	80.5	84.9	89.0	94.9
125	2.13	40.6																		